



UBAYA
UNIVERSITAS SURABAYA

*Mikro***Tik**

Wireless and Wired Bridging using Vlan.

(A case study at Electrical Engineering UBAYA).



Topics of Discussion

- Virtual LAN (VLAN)
- Wired and Wireless Trunk System (Bridge, WDS, Repeater, Tunnel)
- Implementation Vlan @ EE Ubaya
 - Discussion

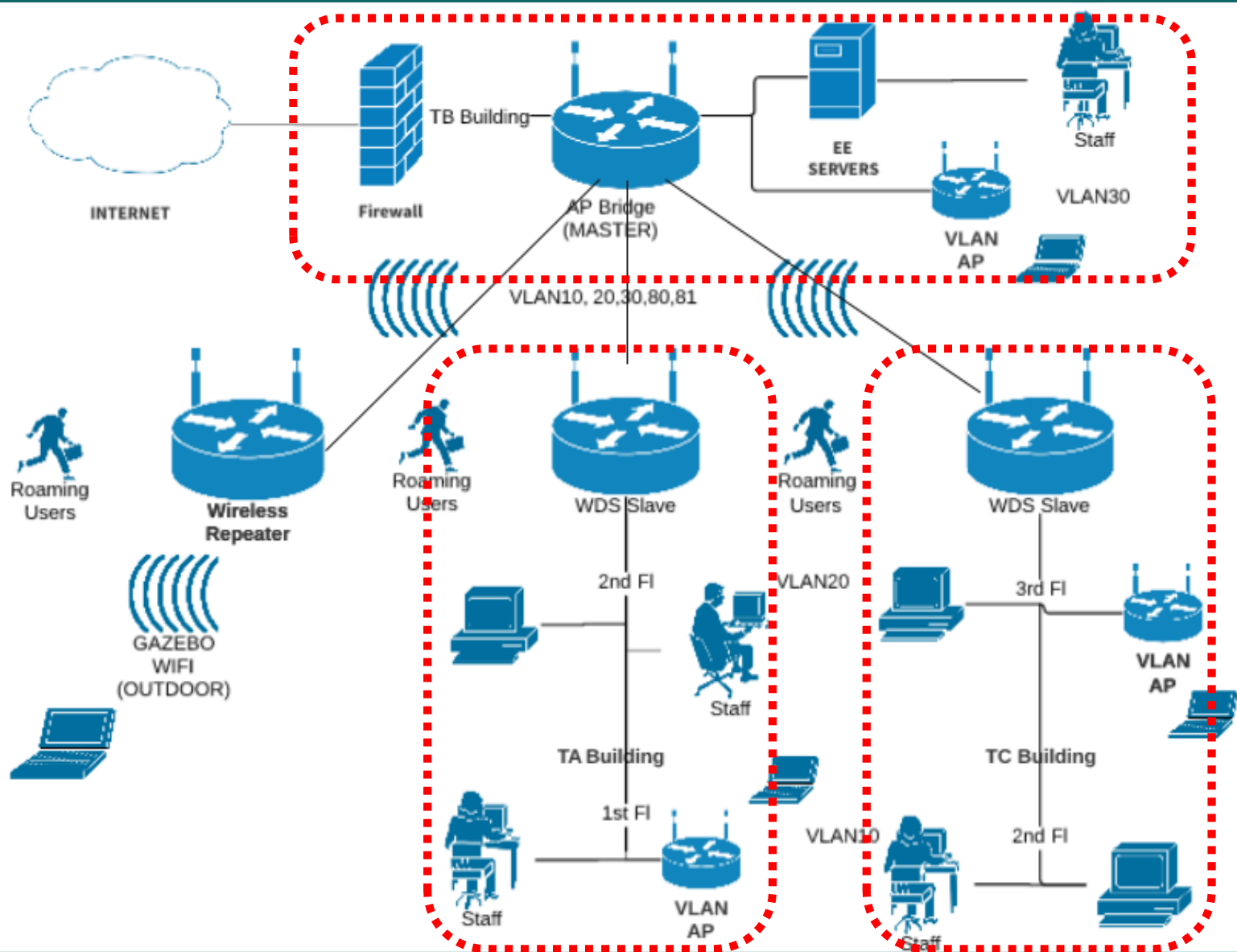



UBAYA
UNIVERSITAS SURABAYA



About Me

(yohanesgunawan@staff.ubaya.ac.id)



- ◆ My Name is Yohanes Gunawan Yusuf, form Indonesia. I am a full time lecturer of University of Surabaya (Ubaya).
- ◆ I have learn and teach in Department of Electrical Engineering (EE) and IT since 1986.
- ◆ MikroTik Academy Trainer for EUTC with certifications: MTCNA, MTCRE, MTCWE, MTCTCE and MTCINE



UBAYA
UNIVERSITAS SURABAYA

University of Surabaya (Ubaya)



UBAYA
UNIVERSITAS SURABAYA

TO BE THE FIRST UNIVERSITY
IN HEART AND MIND



www.daftarjurusan.id



UBAYA
UNIVERSITAS SURABAYA

Universitas Surabaya (Ubaya)





UBAYA
UNIVERSITAS SURABAYA







UBAYA
UNIVERSITAS SURABAYA

Elektro Ubaya

(te.ubaya.ac.id)

 Teknik Elektro Ubaya

 @teknikelektrobaya

 te.ubaya.ac.id

 Teknik Elektro Ubaya

INDUSTRIAL ROBOTIC
DESIGN
TELECOMMUNICATION
NETWORK **DESIGN**

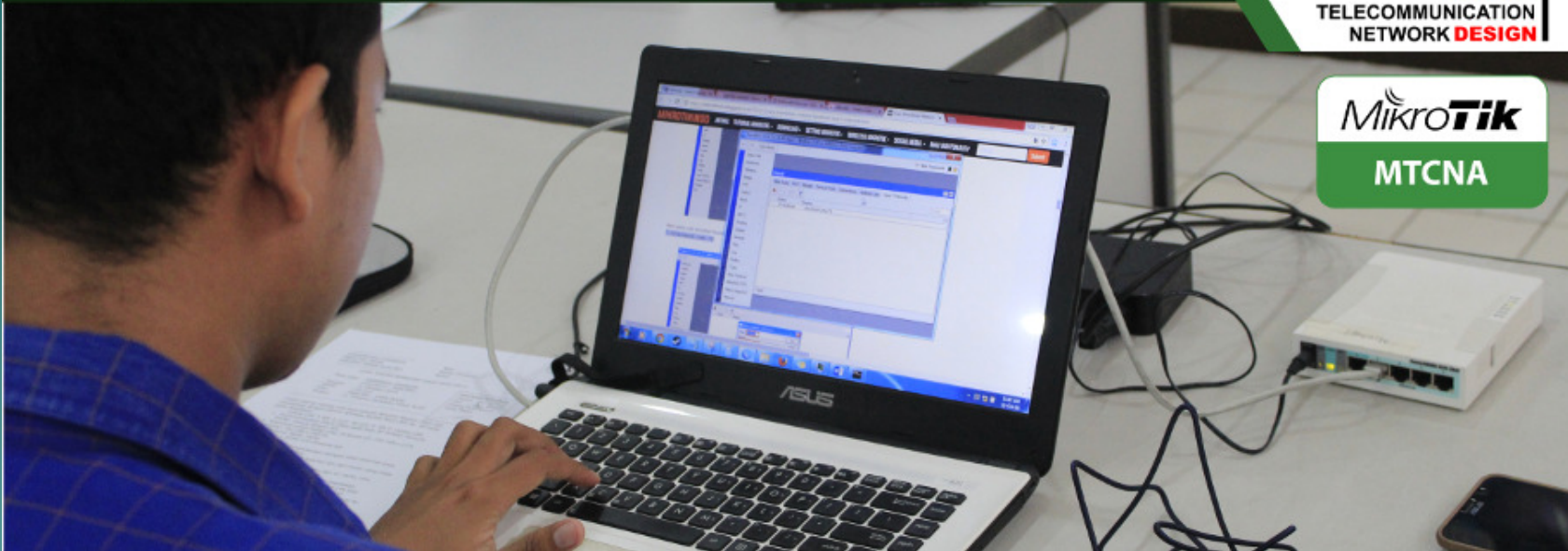

 Teknik Elektro Ubaya

 @teknikelektrobaya

 te.ubaya.ac.id

 Teknik Elektro Ubaya

INDUSTRIAL ROBOTIC
DESIGN
TELECOMMUNICATION
NETWORK **DESIGN**



FIBER OPTIC PERFORMANCE TESTING

 Teknik Elektro Ubaya

 @teknikelektrobaya

 te.ubaya.ac.id

 Teknik Elektro Ubaya

INDUSTRIAL ROBOTIC
DESIGN
TELECOMMUNICATION
NETWORK **DESIGN**

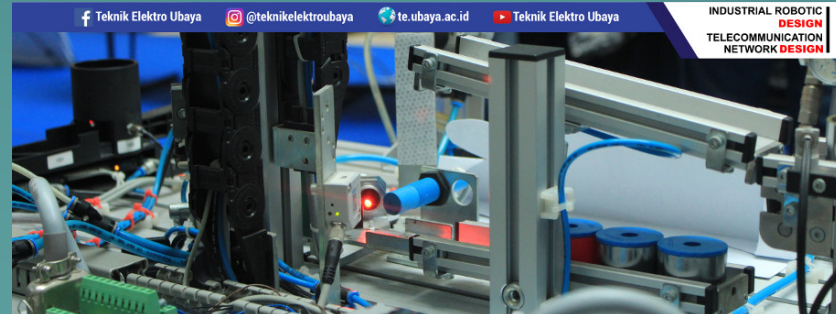



Objective

- ◆ To help you understand **fundamental of Virtual Local Area Network (VLAN)** and implementation in MikroTik router
- ◆ To explain a few **example of implementation of Vlan** in Wireless dan Wired Trunk
- ◆ **To show the implementation VLAN** in Electrical Engineering (EE) - Ubaya

VLAN (Virtual LAN)

- ◆ VLAN is a **Layer 2** method that allows **multiple Virtual LANs on a single physical interface**.
- ◆ You can also transport VLANs over **wired and wireless** links and put multiple VLAN interfaces on a single wireless interface

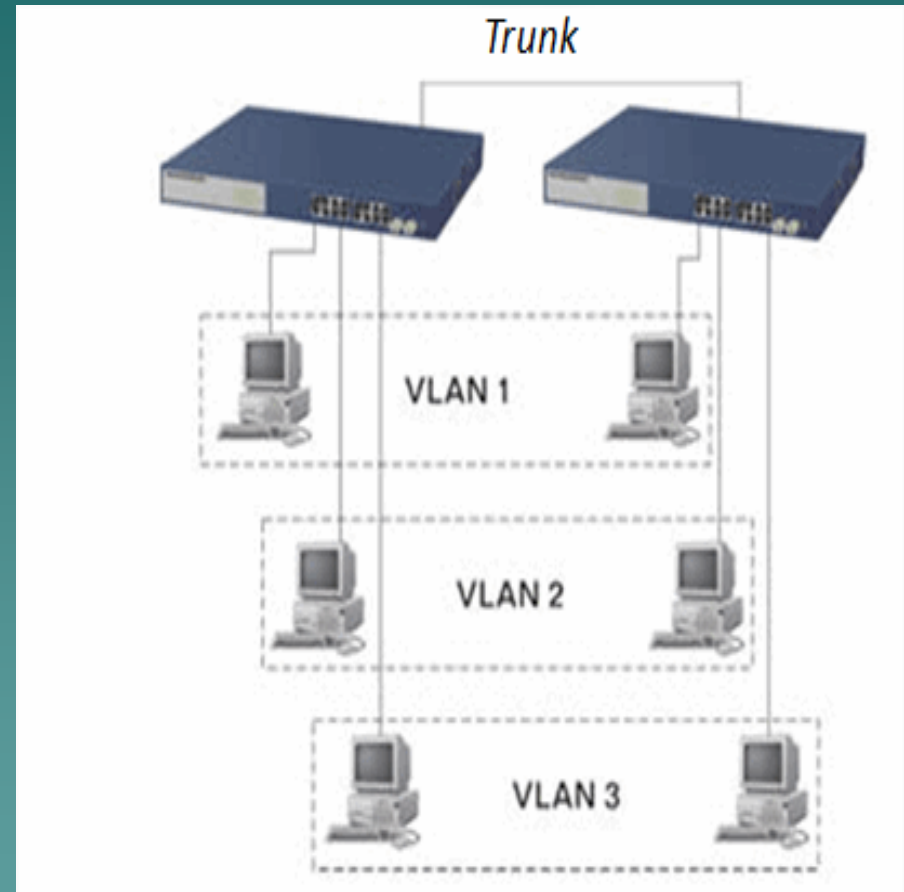

VLAN

- ◆ Each VLAN is **treated as a separate subnet**. It means that by default, a host in a specific VLAN cannot communicate with a host that is a member of another VLAN, although they are connected in the same switch.

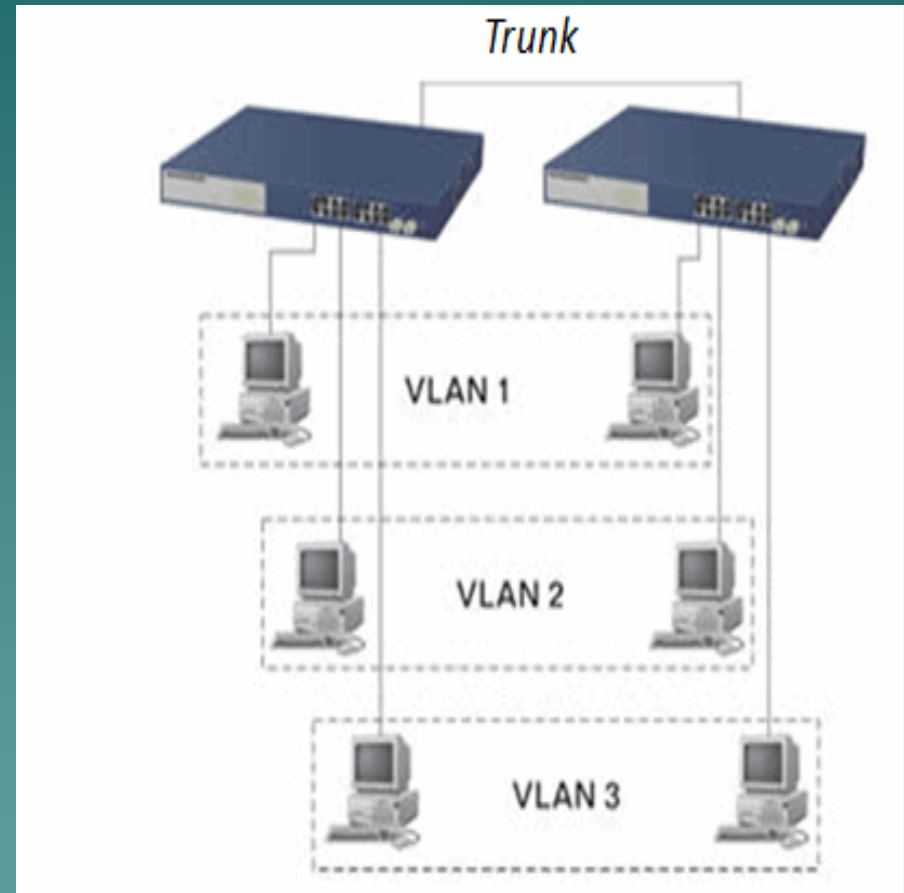

Why VLAN ?

- ◆ We can **create multiple LAN in a single physical interface**, so we will have multiple broadcast domain in a single **physical interface**
- ◆ We can **manage the local network more simple** and manage the different network in one single interface
- ◆ We can create multiple vlan-id in one interface (**Trunk**) OR multiple interface for one vlan-id (**Access**)

IEEE 802.1Q

- ◆ IEEE **802.1Q** is a standardized encapsulation protocol that defines how to insert (tagged) a **four-byte VLAN identifier** into Ethernet header.
- ◆ RouterOS supports up to **4095 VLAN** interfaces, each with a unique **VLAN ID**, per interface (exception: 0,1 and 4095)

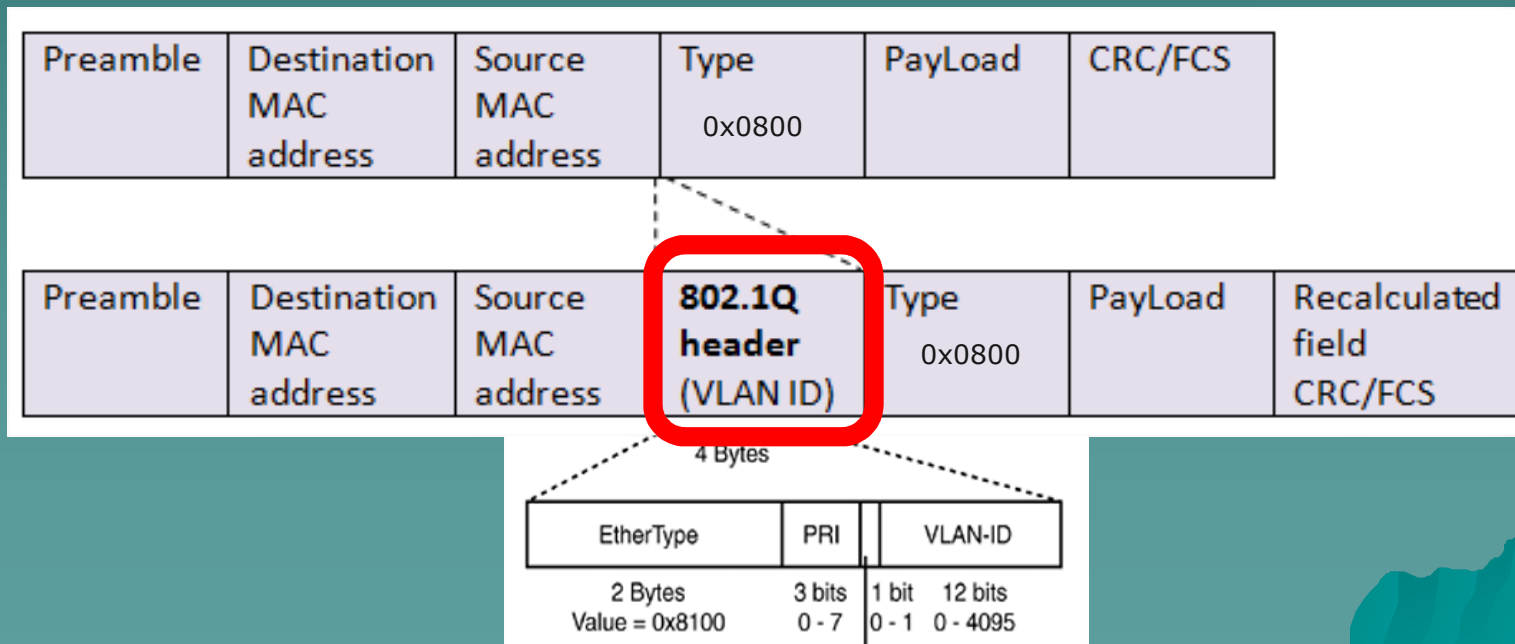

IEEE 802.1Q

Tagged

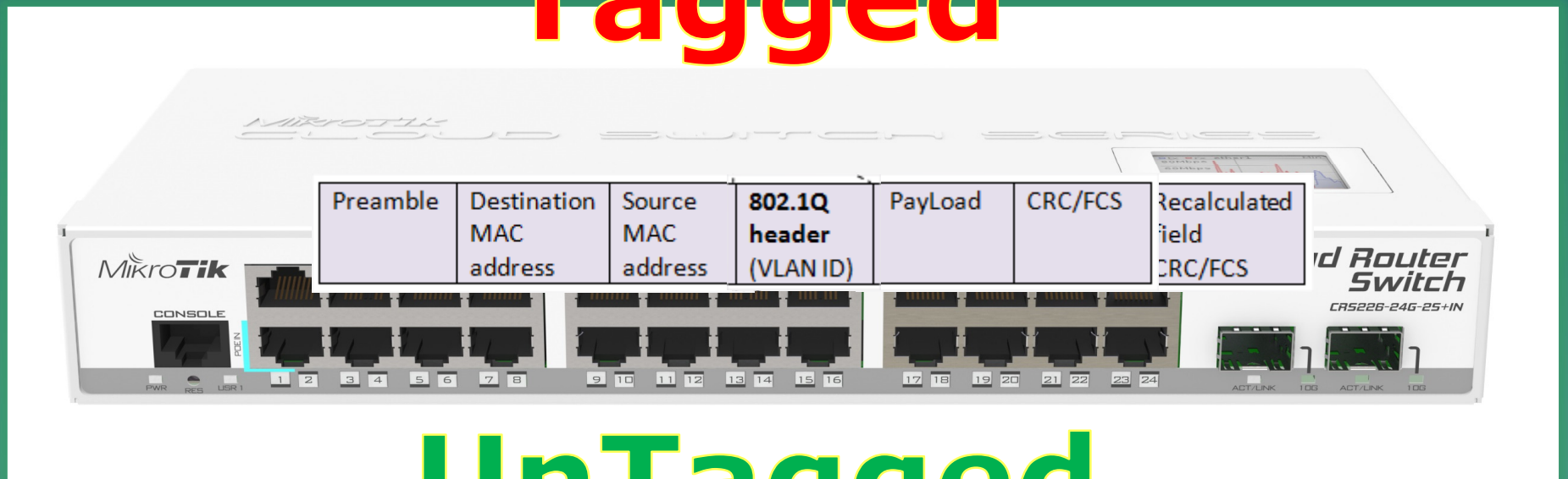

UnTagged

Ether Type: 0x0800 (IP4) , 0x8100 (802.1Q)

VLAN Access and Trunk

A trunk carries **Tagged** packets between switches and/or router.

TRUNK (VLAN 10, VLAN 20, VLAN 30)

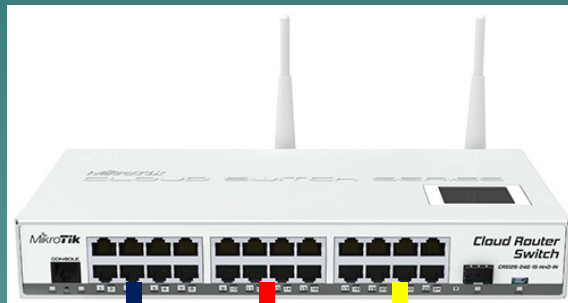

ACCESS

VLAN 10 20 30

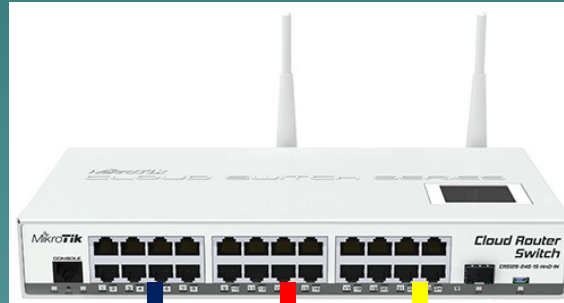

ACCESS

VLAN10 20 30

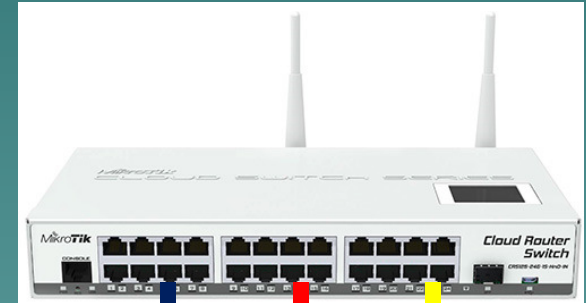

ACCESS

VLAN10 20 30

Access carries **Untagged** packets to end devices or host (PC, laptop, Servers, etc)

VLAN Access and Trunk

Tagged Vlan ID

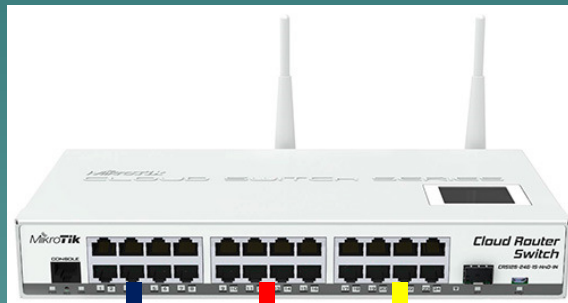

ACCESS

VLAN 10 20 30

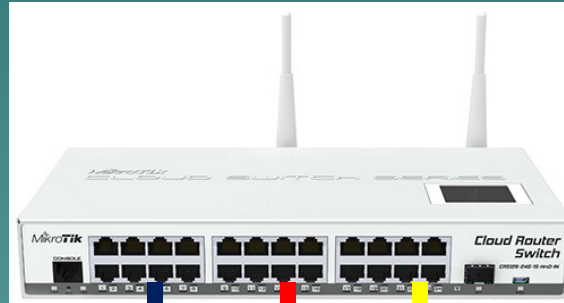

ACCESS

VLAN10 20 30

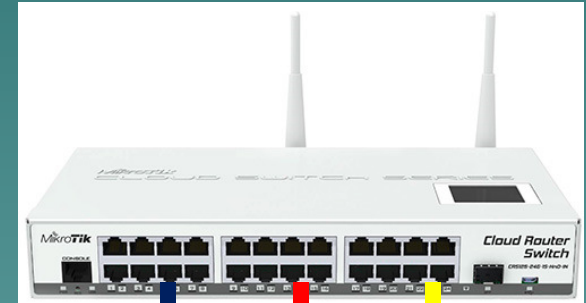

ACCESS

VLAN10 20 30

VLAN Access and Trunk

TRUNK (VLAN 10, VLAN 20, VLAN 30)

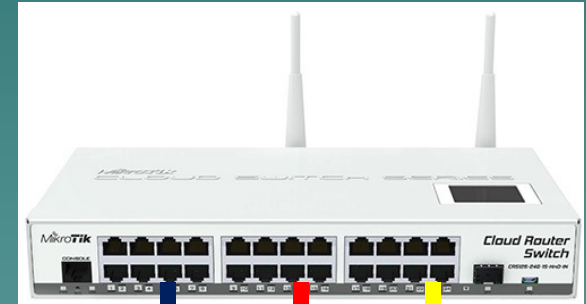
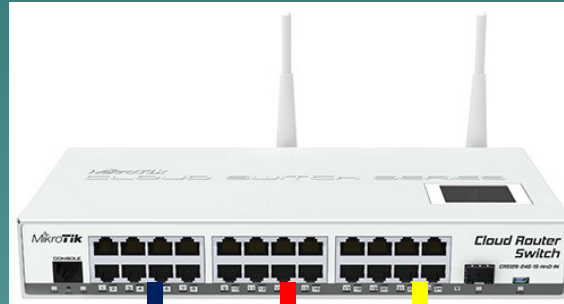
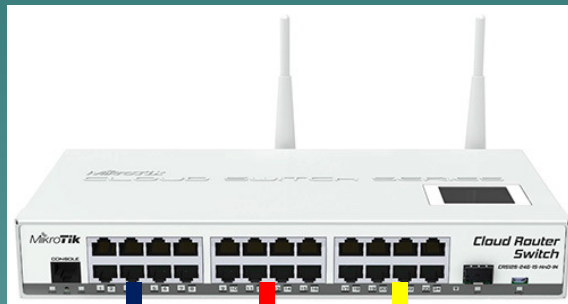

ACCESS ACCESS ACCESS
Untagged Vlan ID
VLAN 10 20 30 VLAN10 20 30 VLAN10 20 30

Tagged and Untagged Vlan ID

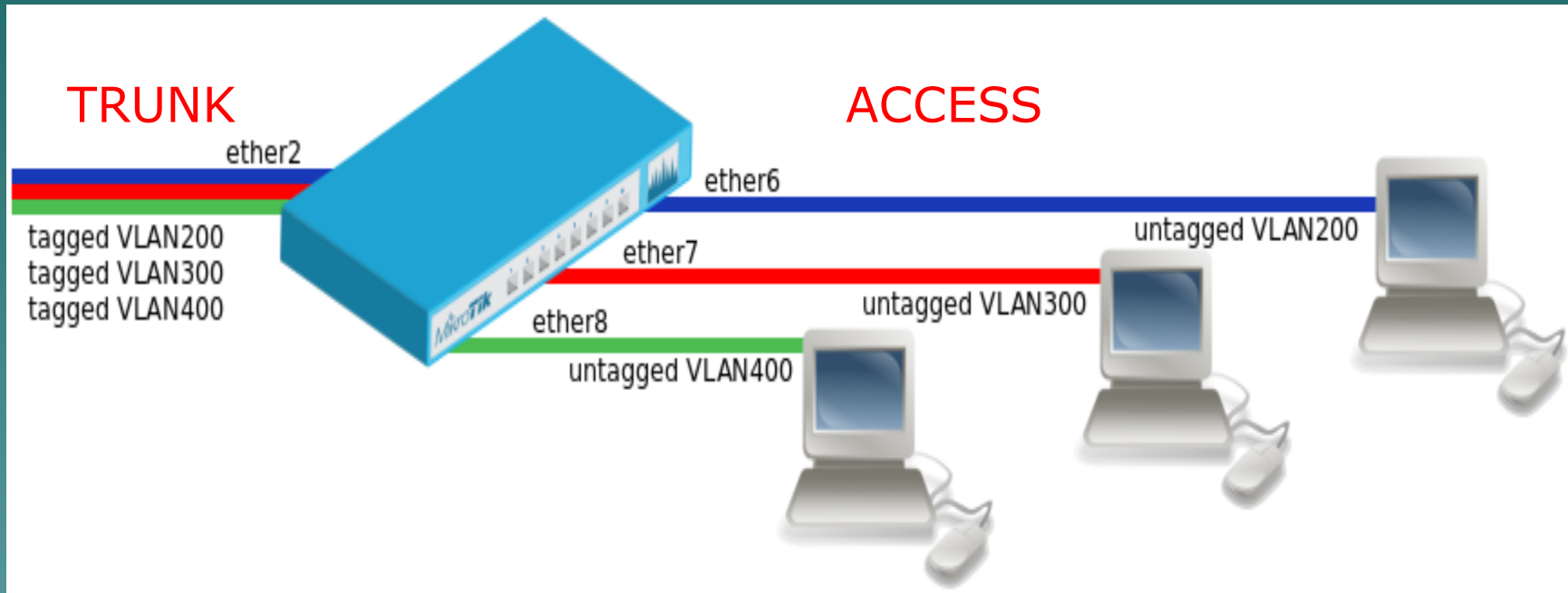

- ◆ Vlan ID: Tagged on Trunk, then Untagged on Access

How to VLAN?

1. Create bridges for **Trunk** and bridges for **each Access**
2. Add **Interfaces VLAN on the Trunk Bridge** and put ethernet (tagged) port into **Trunk Bridge Port**
3. Add **untagged** vlan interface and ethernet (untagged) **ports** into **Access Bridges Port.**

1) Create Bridges

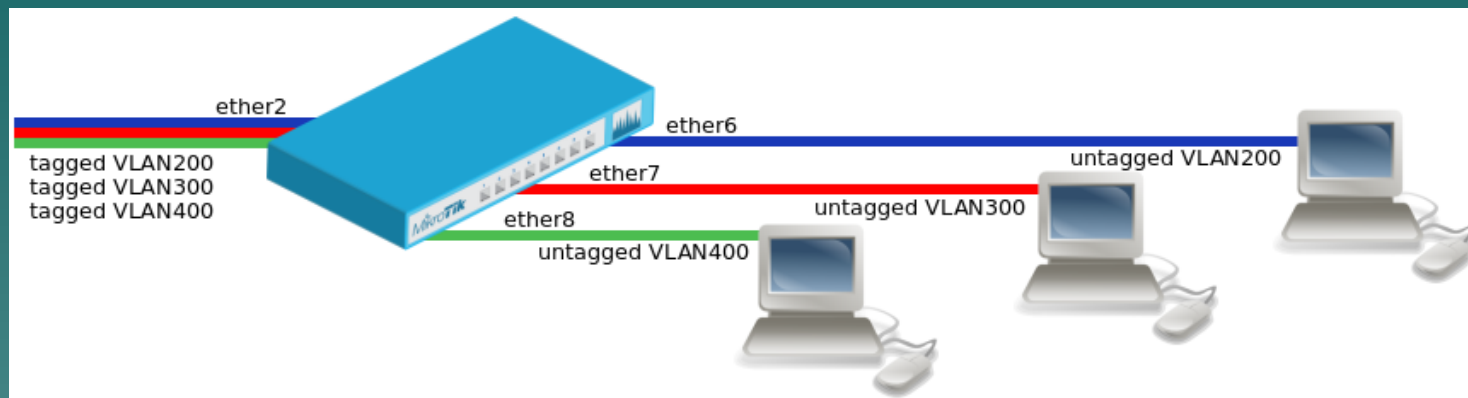

Create bridges for **Trunk** and bridges for **each Access**

```
/interface bridge
add fast-forward=no name=bridge-trunk
add fast-forward=no name=bridge-vlan200
add fast-forward=no name=bridge-vlan300
add fast-forward=no name=bridge-vlan400
```

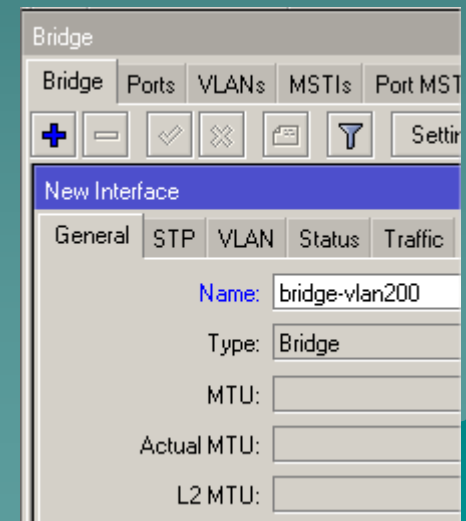

2) Create VLAN @BridgeTrk

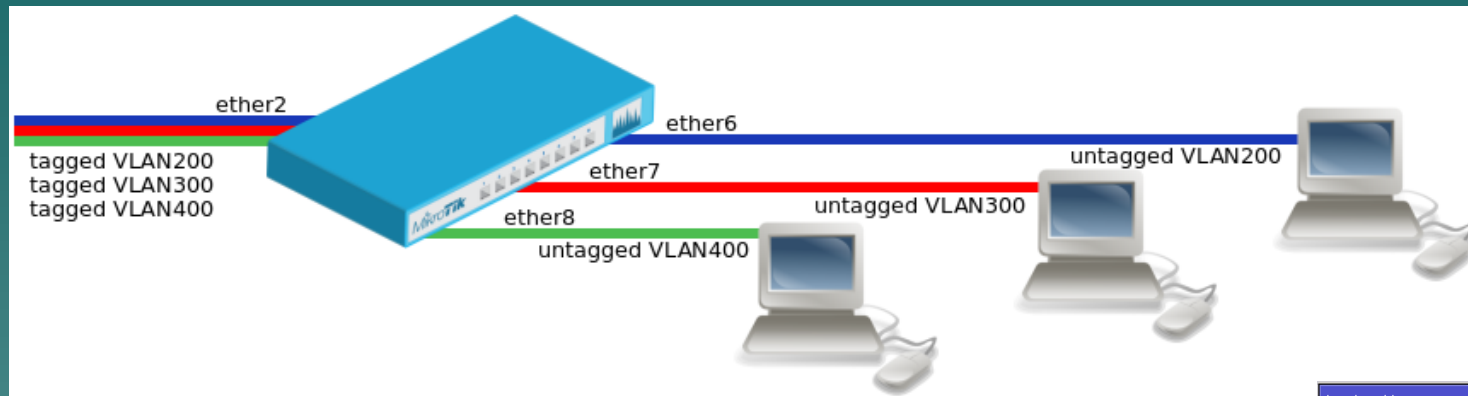

Add **Interfaces VLAN** on the Trunk Bridge and put ethernet (tagged) port into **Trunk Bridge Port**

```
/interface vlan
add interface=bridge-trunk name=eth2-vlan200 vlan-id=200
add interface=bridge-trunk name=eth2-vlan300 vlan-id=300
add interface=bridge-trunk name=eth2-vlan400 vlan-id=400
```

```
/interface bridge port
add bridge=bridge-trunk interface=ether2
```

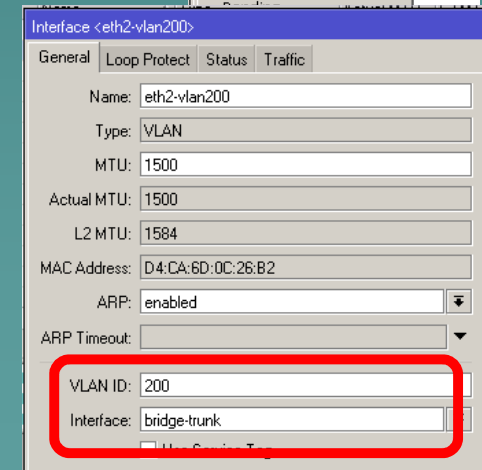
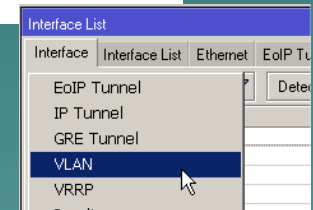

3) Untagged VLAN @BridgeAcc

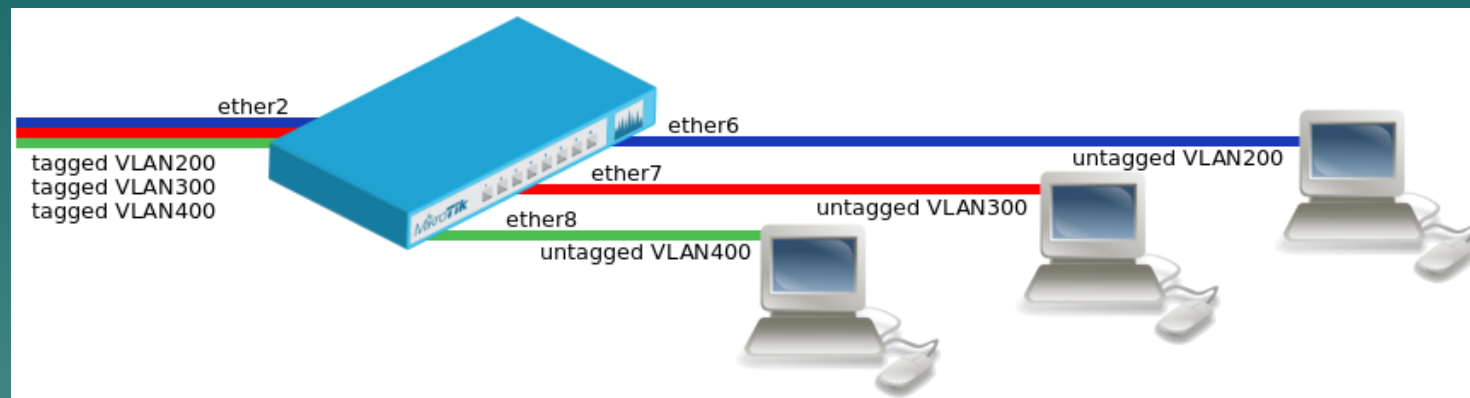

Add **untagged** vlan interface and ethernet (untagged) ports into **Access Bridges Port**.

```
/interface bridge port  
  
add bridge=bridge-vlan200 interface=eth2-vlan200  
add bridge=bridge-vlan200 interface=ether6  
  
add bridge=bridge-vlan300 interface=eth2-vlan300  
add bridge=bridge-vlan300 interface=ether7  
  
add bridge=bridge-vlan400 interface=eth2-vlan400  
add bridge=bridge-vlan400 interface=ether8
```

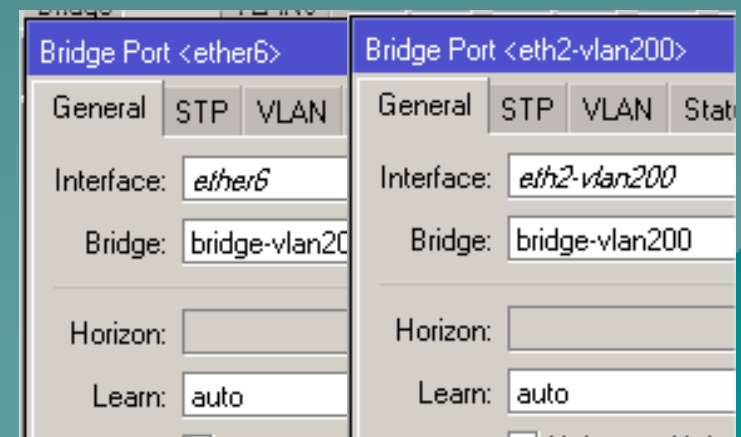

Bridge VLAN Filtering

(since RouterOS 6.41 AND support Hardware Offload)

1. Create a **bridge** with **disabled** vlan-filtering (no)
2. Add **Bridge Ports** and specify PVID for **VLAN access ports** to assign their untagged traffic to the intended VLAN.
3. Add **Bridge VLAN** entries and specify **tagged and untagged ports** in them.
4. In the end, when VLAN configuration is complete, **enable** vlan-filtering.

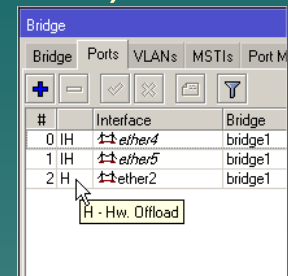

#	Interface	Bridge
0	H ether4	bridge1
1	H ether5	bridge1
2	H ether2	bridge1

H - Hw. Offload

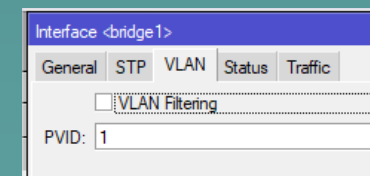

<https://wiki.mikrotik.com/wiki/Manual:Interface/Bridge>

Bridge VLAN Filtering

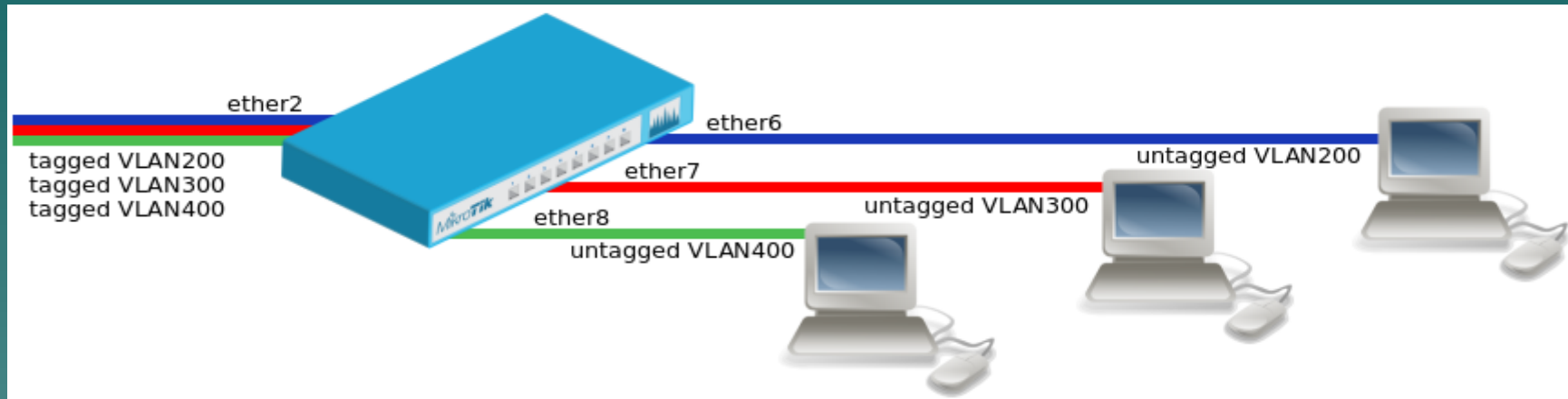

```
/interface bridge
add name=bridge1 vlan-filtering=no
```

```
/interface bridge port
add bridge=bridge1 interface=ether2
add bridge=bridge1 interface=ether6 pvid=200
add bridge=bridge1 interface=ether7 pvid=300
add bridge=bridge1 interface=ether8 pvid=400
```

```
/interface bridge vlan
add bridge=bridge1 tagged=ether2 untagged=ether6 vlan-ids=200
add bridge=bridge1 tagged=ether2 untagged=ether7 vlan-ids=300
add bridge=bridge1 tagged=ether2 untagged=ether8 vlan-ids=400
```

```
/interface bridge set bridge1 vlan-filtering=yes
```

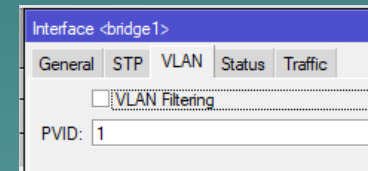

Reading Suggestion

- ◆ https://wiki.mikrotik.com/wiki/Manual:Interface/Bridge#Bridge_VLAN_Filtering (edited 8 October 2018)
- ◆ https://wiki.mikrotik.com/wiki/Manual:Interface/Bridge#Management_port (edited 8 October 2018)
- ◆ https://wiki.mikrotik.com/wiki/Manual:Layer2_misconfiguration (edited 22 Agustus 2018)
- ◆ Youtube: https://www.youtube.com/watch?v=ZM Mpza-O7_w (VLAN processing in New bridge implementation by: Andis Arins, April 2018)

Hybrid VLAN Ports

- ◆ An Hybrid Vlan port is a special mode that allow untagged and tagged packets on the same port.

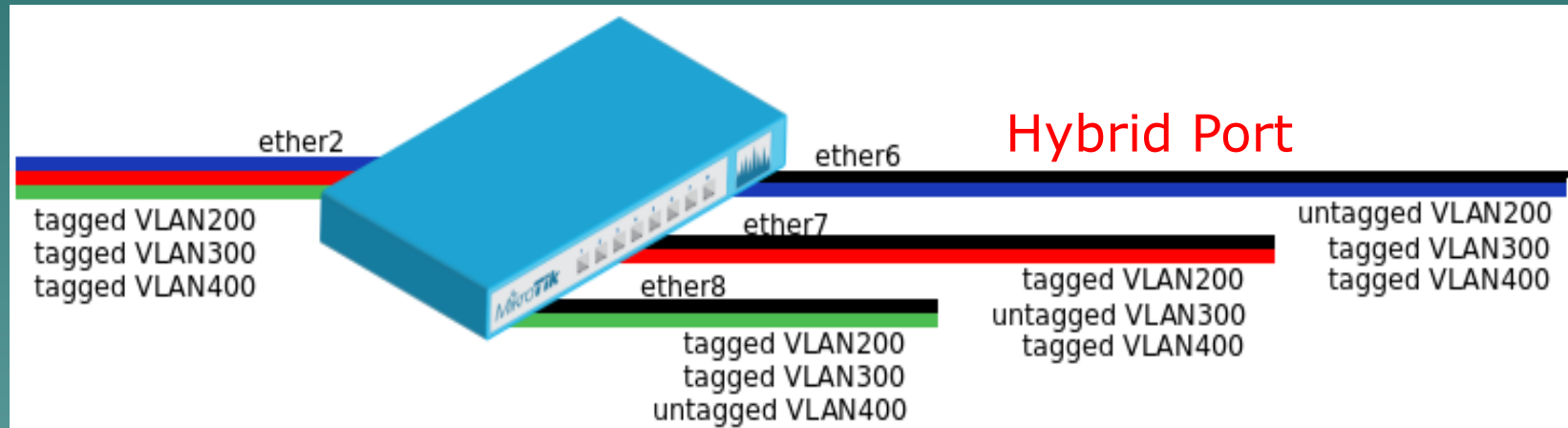

```
/interface bridge vlan
add bridge=bridge1 tagged=ether2,ether7,ether8 untagged=ether6 vlan-ids=200
add bridge=bridge1 tagged=ether2,ether6,ether8 untagged=ether7 vlan-ids=300
add bridge=bridge1 tagged=ether2,ether6,ether7 untagged=ether8 vlan-ids=400
```

Inter VLAN Routing

- Routing process between VLANs is called Inter-VLAN Routing. Communication between VLAN must be Routed.
- Configure VLAN interfaces on the **bridge1** to allow handling of tagged VLAN traffic at routing level

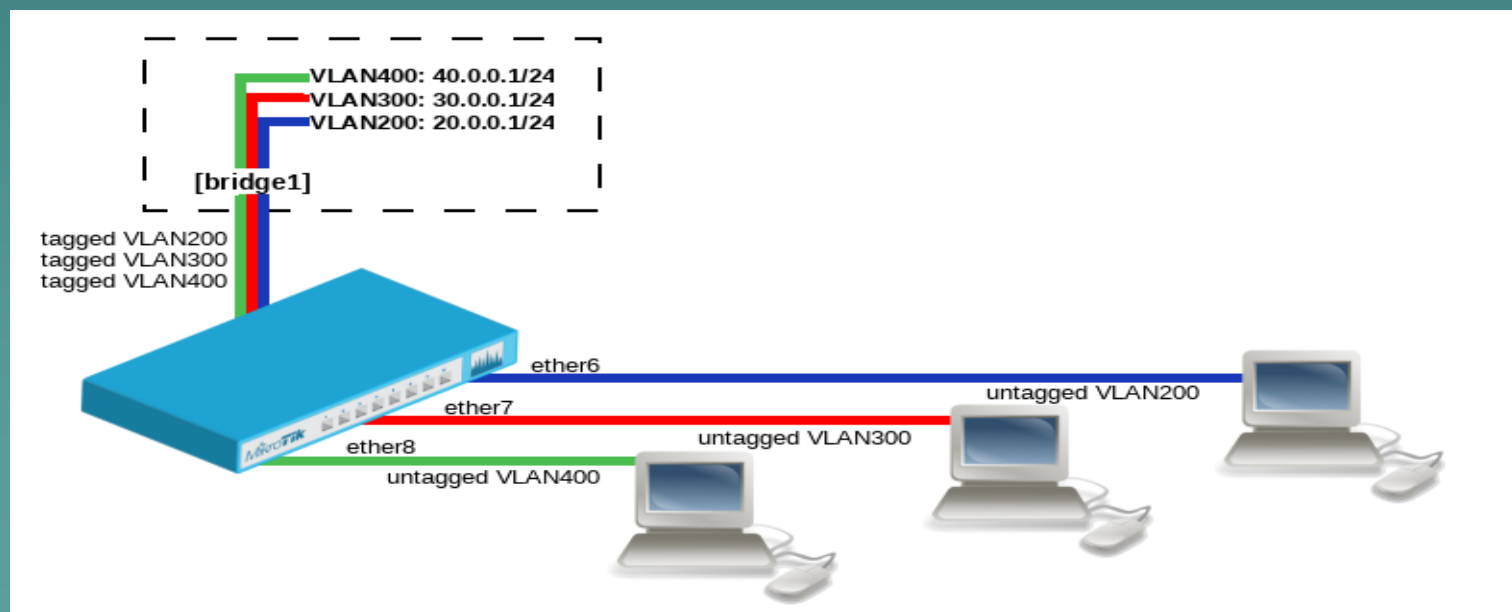

Wired Trunk



WIRED TRUNK:
Ether 1: Vlan ID
110,120,130

ACCESS PORTS Vlan:
Wlan 1:
110: 192.168.110.0/24
Ether 2:
120: 192.168.120.0/24
Ether 3-5:
130: 192.168.130.0/24

Wireless Trunk



WIRELESS TRUNK:

Wlan1 : Vlan 110,120,130:
192.168.100.0/24

ACCESS PORTS Vlan:

Ether 1:

110: 192.168.110.0/24

Ether 2:

120: 192.168.120.0/24

Ether 3-5:

130: 192.168.130.0/24

1) Create Bridges

Create bridges for trunk and bridges for each access VLAN

```
/interface bridge  
add fast-forward=no name=bridge1trunk  
add fast-forward=no name=bridge2vlan110  
add fast-forward=no name=bridge2vlan120  
add fast-forward=no name=bridge2vlan130
```

2) Create VLAN @BridgeTrk

Add **Interfaces VLAN on the Trunk Bridge** and put ethernet/wlan (tagged) port into **Trunk Bridge Port**
Give Name and unique VLAN ID (ex:110, not 0,1 or 4095)

```
/interface vlan
```

```
add interface=bridge1trunk name=vlan110 vlan-id=110
```

```
add interface=bridge1trunk name=vlan120 vlan-id=120
```

```
add interface=bridge1trunk name=vlan130 vlan-id=130
```

```
/interface bridge port
```

```
add bridge=bridge1trunk interface=wlan1
```

TRUNK

3) Untagged VLAN @BridgeAcc

Add **untagged** vlan interface and ethernet (untagged) **ports** into **Access Bridges Port**.

```
/interface bridge port
```

```
add bridge=bridge2vlan110 interface=vlan110
```

```
add bridge=bridge2vlan120 interface=ether2
```

```
add bridge=bridge2vlan120 interface=vlan120
```

```
add bridge=bridge2vlan130 interface=ether3
```

```
add bridge=bridge2vlan130 interface=vlan130
```

```
add bridge=bridge2vlan130 interface=ether4
```

```
add bridge=bridge2vlan130 interface=ether5
```

ACCESS

VLAN in MikroTik

The screenshot displays the MikroTik WinBox interface with several windows open to configure VLANs and bridges. A red arrow points from the 'Interface List' window to the 'Interface <vlan110>' configuration window.

Interface List

Name	Type	Actual MTU	L2 MTU	Tx
bridge1trunk	Bridge	1500	1600	
vlan110	VLAN	1500	1596	
vlan120	VLAN	1500	1596	
vlan130	VLAN	1500	1596	
bridge2vlan110	Bridge			
bridge2vlan120	Bridge			
bridge2vlan130	Bridge			
ether1	Ethernet			
ether2	Ethernet			
ether3	Ethernet			
ether4	Ethernet			
ether5	Ethernet			
wlan1	Wireless			

Interface <vlan110>

General | Loop Protect | Status | Traffic

Name: vlan110
Type: VLAN
MTU: 1500
Actual MTU: 1500
L2 MTU: 1596
MAC Address: 4C:5E:0C:5F:D3:3D
ARP: enabled
ARP Timeout:

VLAN ID: 110
Interface: bridge1trunk
 Use Service Tag

Bridge

Bridge | Ports | VLANs | MSTIs | Port MST Overrides | Filter

#	Interface	Bridge	Horizo
0	wlan1	bridge1trunk	
1	ether1	bridge2vlan110	
2	vlan110	bridge2vlan110	
3	ether2	bridge2vlan120	
4	vlan120	bridge2vlan120	
5	ether3	bridge2vlan130	
7	ether4	bridge2vlan130	
8	ether5	bridge2vlan130	
6	vlan130	bridge2vlan130	

Address List

Address	Network	Interface
192.168.100.99/24	192.168.100.0	wlan1
192.168.110.1/24	192.168.110.0	bridge2vlan110
192.168.120.1/24	192.168.120.0	bridge2vlan120
192.168.130.1/24	192.168.130.0	bridge2vlan130

Wireless Trunk



- ◆ Wireless Bridge (AP-Bridge, Station-Bridge) -> bridge to ethernet, etc
- ◆ Wireless Distribution System -> Roaming
- ◆ Wireless Repeater -> Extend Range
- ◆ Tunnel (EoIP, PPTP with BCP) -> Secured Tunneling

Wireless Bridge



R1

Act as usual **AP Bridge** with specific Band Frequency, SSID and Security Profile
Bridge between wlan and ethernet

R2

Act as **Station bridge** for selected Access Point (AP)
Bridge between wlan and ethernet

Bridge VLAN on Wireless Bridge

It is done by creating Vlan Interface (Vlan110, Vlan 120, Vlan 130) on Wireless-Bridge (ie: bridge2wlan-ether)

```
/interface vlan
```

```
add interface=bridge2wlan-ether name=vlan110 vlan-id=110
```

```
add interface=bridge2wlan-ether name=vlan120 vlan-id=120
```

```
add interface=bridge2wlan-ether name=vlan130 vlan-id=130
```

```
/interface bridge port
```

```
add bridge=bridge2wlan-ether interface=wlan1
```

WDS (Master - Slave)



- ◆ WDS Master: as AP-Bridge with specific SSID, Band, Freq and Security Profile
- ◆ WDS Slave: same as ap-bridge, but scan for AP with the same ssid and establishes WDS link.
- ◆ WDS Master and Slave **MUST BE Bridge** into WDS Default Bridge

Create WDS Bridge

- ◆ Create WDS Default bridge with specific name, like: bridge2wds for both Master WDS and Slave WDS

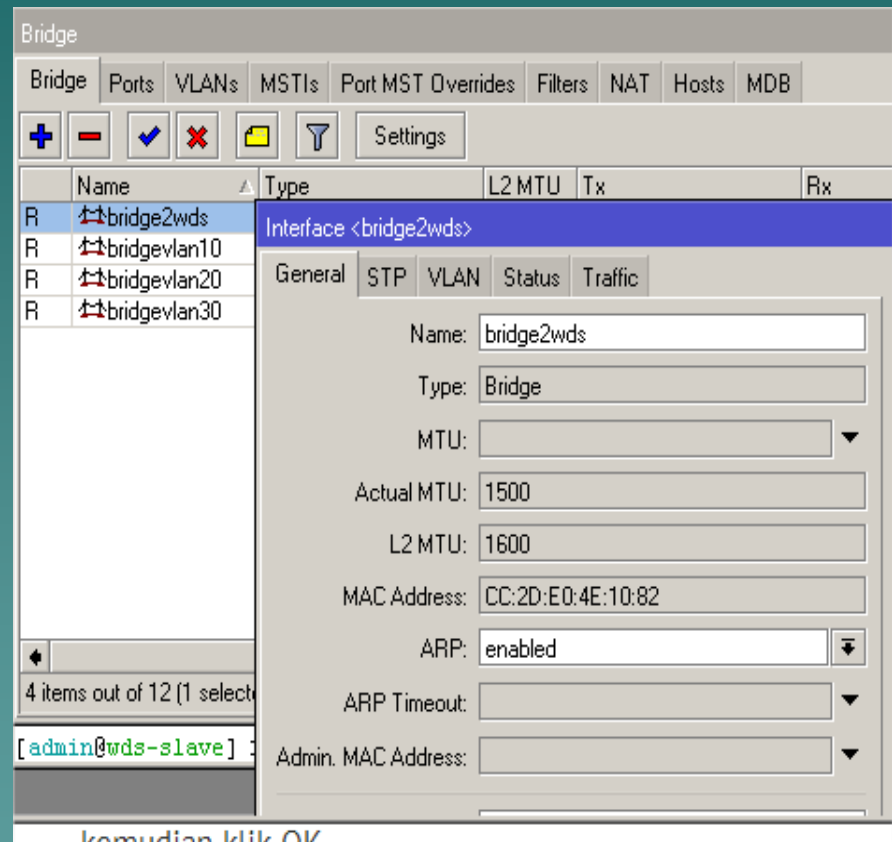

Create WDS Master

- ◆ Enable Wlan as **AP-Bridge** with specific Security Profile
- ◆ In tab WDS, set **WDS mode Static**
- ◆ Set WDS Default Bridge to created bridge before (ie: bridge2wds).

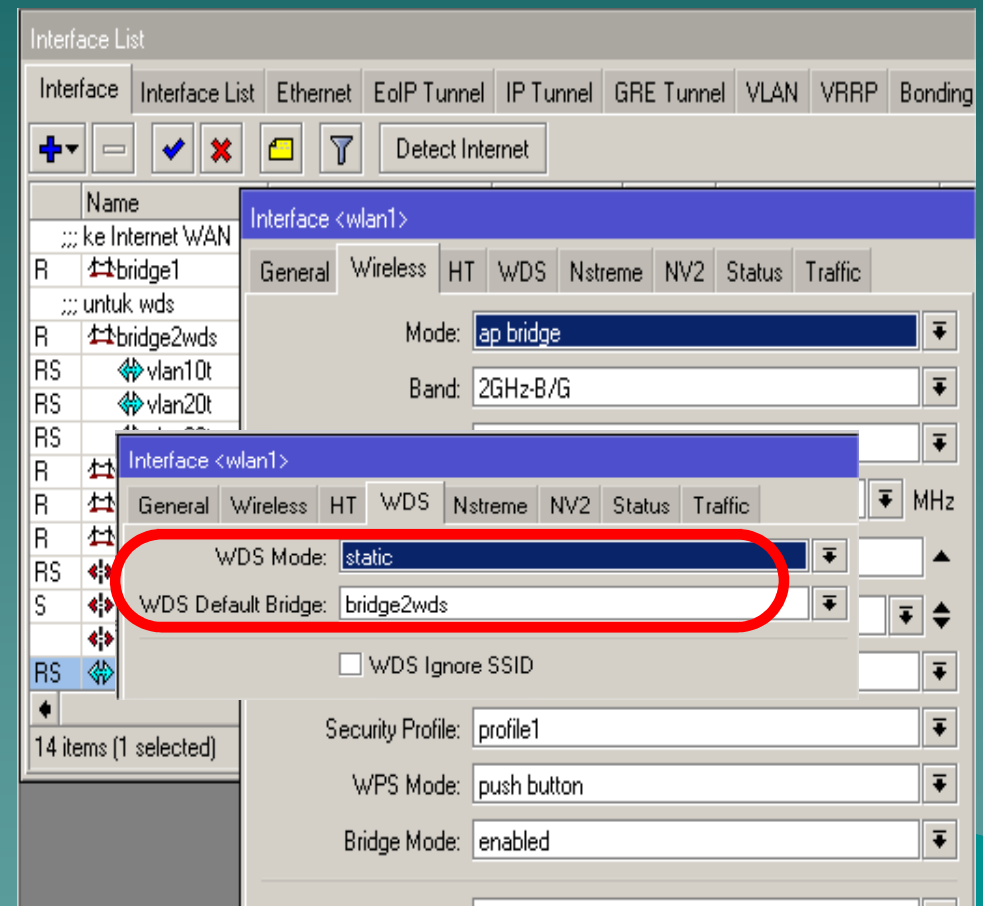

Create WDS Master

- ◆ In **Wireless Menu** at Wifi Interface Add (+) WDS Interface on Wlan as Master Interface
- ◆ Fill WDS Address for WDS **Slave MAC Address**

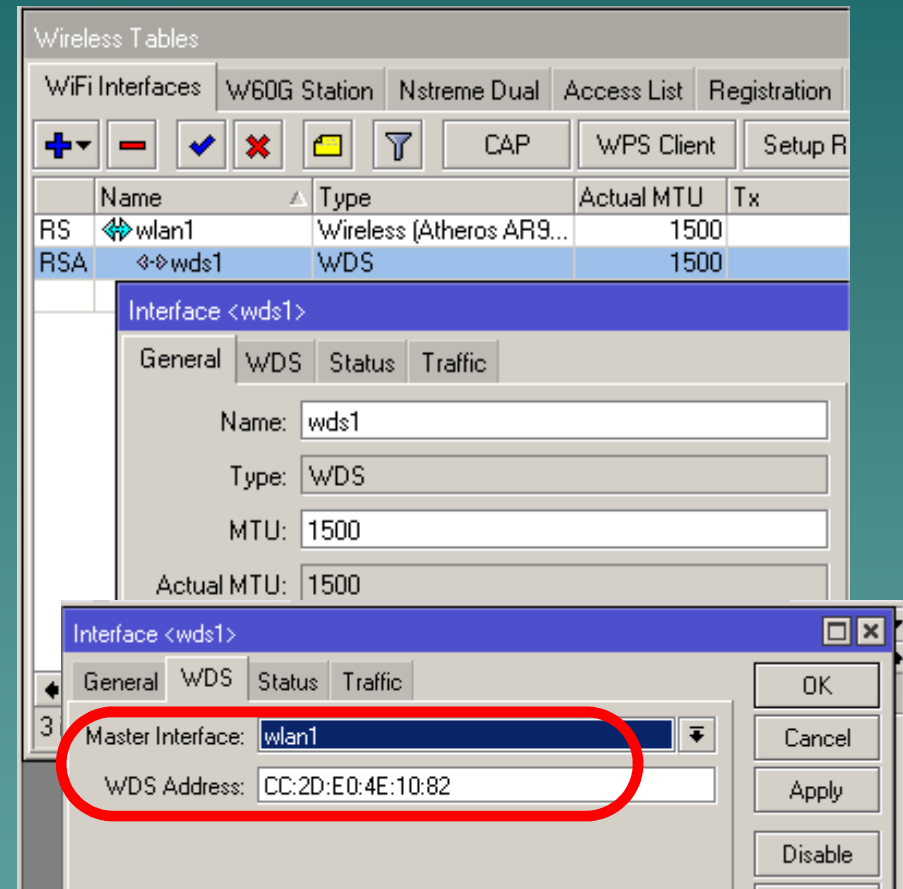

Create WDS Slave

- ◆ Enable Wlan as **WDS-Slave**
- ◆ Tab WDS, set **WDS mode Static**
- ◆ Set WDS Default Bridge to created bridge before (ie: bridge2wds).

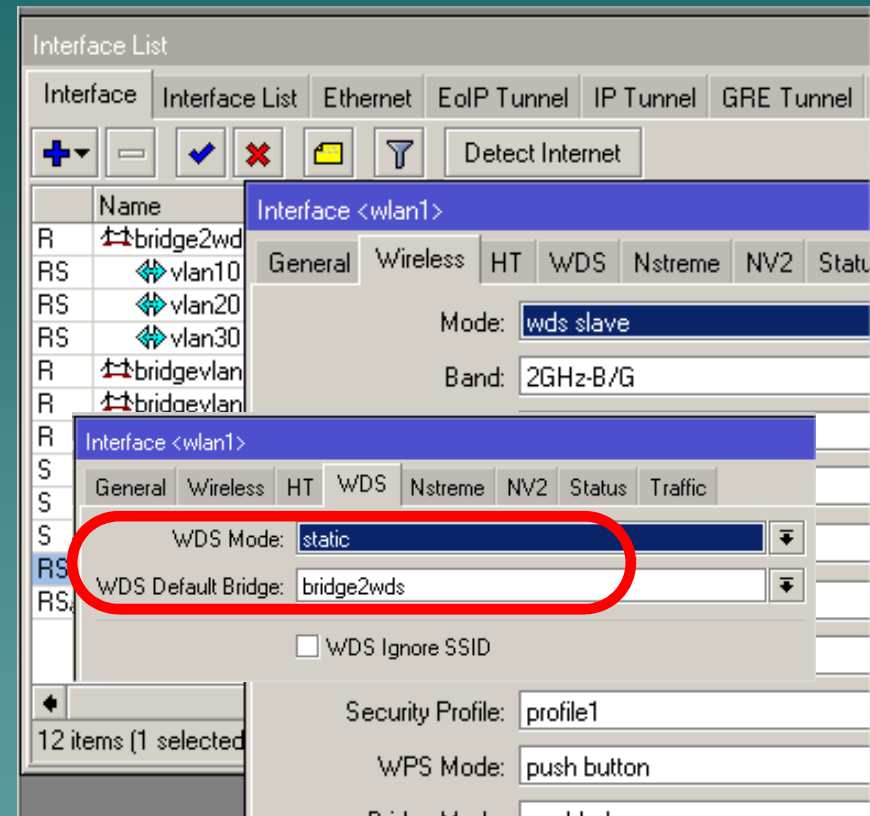

Create WDS Slave

- ◆ In **Wireless Menu** at Wifi Interface Add (+) WDS Interface on Wlan as Master Interface
- ◆ Fill WDS Address for WDS **Master MAC Address**

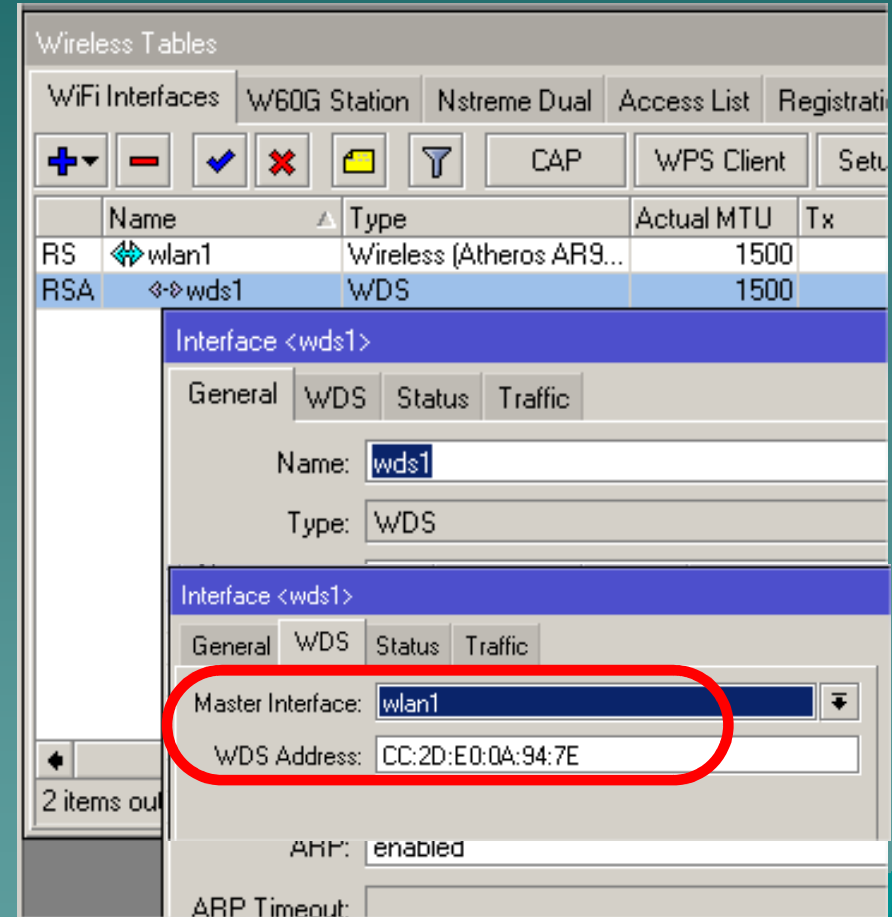

RSA (Running, Slave, Active) WDS

Interface List

Interface Interface List Ethernet EoIP Tunnel IP Tunnel GRE Tunnel VLAN VRRP Bonding L

+ - ✓ ✗ 📁 🏠 Detect Internet

	Name	Type	Actual MTU	L2 MTU	Tx	Rx	T
	ether15	Ethernet	1500	1588	0 bps	0 bps	
	ether16	Ethernet	1500	1588	0 bps	0 bps	
S	ether17	Ethernet	1500	1588	0 bps	0 bps	
	ether18	Ethernet	1500	1588	0 bps	0 bps	
	ether19	Ethernet	1500	1588	0 bps	0 bps	
	ether20	Ethernet	1500	1588	0 bps	0 bps	
	ether21	Ethernet	1500	1588	0 bps	0 bps	
	ether22	Ethernet	1500	1588	0 bps	0 bps	
	ether23	Ethernet	1500	1588	0 bps	0 bps	
	ether24	Ethernet	1500	1588	0 bps	0 bps	
	sfp1	Ethernet	1500	1588	0 bps	0 bps	
R	wlan1	Wireless (Atheros AR93...	1500	1600	525.7 kbps	25.5 kbps	
RSA	wds1	WDS	1500	1600	525.7 kbps	25.5 kbps	

R - running, S - slave, A - active

34 items (1 selected)

Bridge VLAN on WDS

- ◆ It is done by creating Vlan Interface (Vlan10, Vlan 20, Vlan 30) on WDS Bridge Default (ie: bridge2wds)

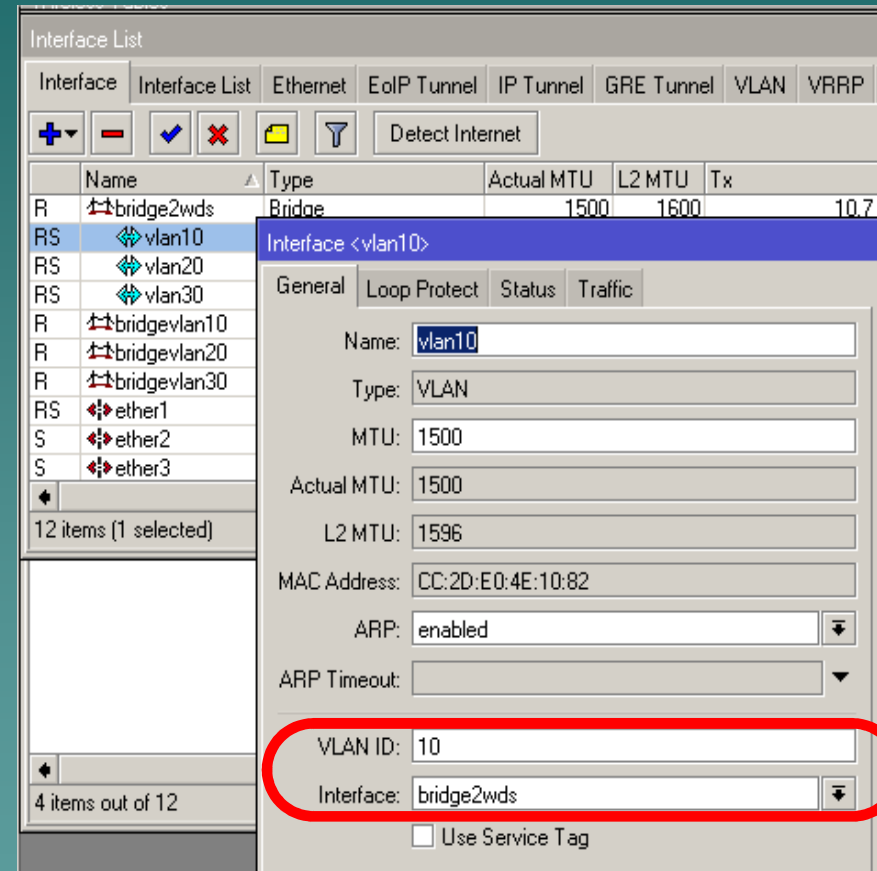

Wireless Repeater

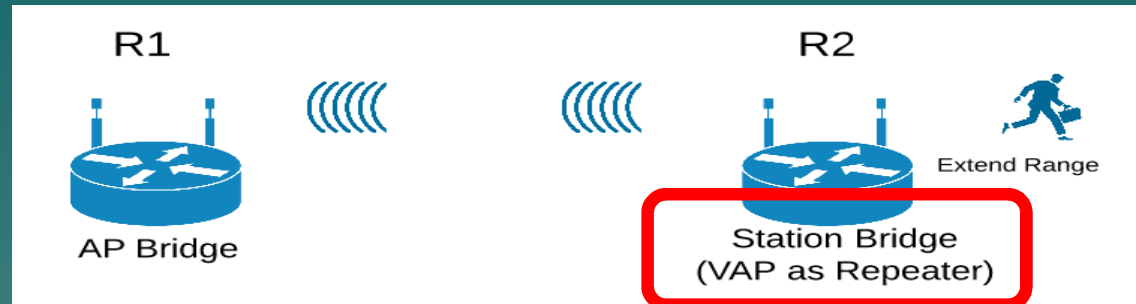

R1

Act as usual **AP Bridge** with specific Band Frequency, SSID

R2

Set wlan1 as **Station bridge** for selected Access Point (AP)
Create **Virtual AP (wlan2)** from master interface wlan1
Bridge between wlan1 and wlan2 as Trunk .OR.
Bridge wlan2 to Access Bridge as Access Port

Bridge VLAN on Wireless Repeater

It is done by creating Vlan Interface (Vlan110, Vlan 120, Vlan 130) on Wireless Repeater-Bridge (ie: bridge1wireless)

```
/interface vlan  
add interface=bridge1wireless name=vlan110 vlan-id=110  
add interface=bridge1wireless name=vlan120 vlan-id=120  
add interface=bridge1wireless name=vlan130 vlan-id=130
```

```
/interface bridge port  
add bridge=bridge1wireless interface=wlan1  
add bridge=bridge1wireless interface=wlan2
```

Wireless Tunnel



```
/interface bridge
add fast-forward=no name=bridge3eoip
/interface eoip
add mac-address=02:A7:59:B2:DB:CB name=eoip-tunnel1
remote-address=192.168.80.1 tunnel-id=111
/interface vlan
add interface=bridge3eoip name=vlan300 vlan-id=300
/interface bridge port
add bridge=bridge2vlan300 interface=eoip-tunnel1
add bridge=bridge2vlan300 interface=ether3
```

Bridge VLAN on Wireless Tunnel

It is done by creating Vlan Interface (ie: Vlan 300) on Wireless Tunnel-Bridge (ie: bridge3eoip)

```
/interface vlan  
add interface=bridge3eoip name=vlan300 vlan-id=300
```

```
/interface bridge port  
add bridge=bridge2vlan300 interface=eoip-tunnel1  
add bridge=bridge2vlan300 interface=ether3
```

Implementation @ EE Ubaya

- ◆ There are 3 building TA, TB, TC and Outdoor
- ◆ Between building connected wired and wirelessly.
- ◆ There is a or several Main Router Board (RB) or Switch in each building
- ◆ From the Main RB is connected to Ethernet to some extended RB or switches and several APs

Wireless Scope Area





The Implemented Topology

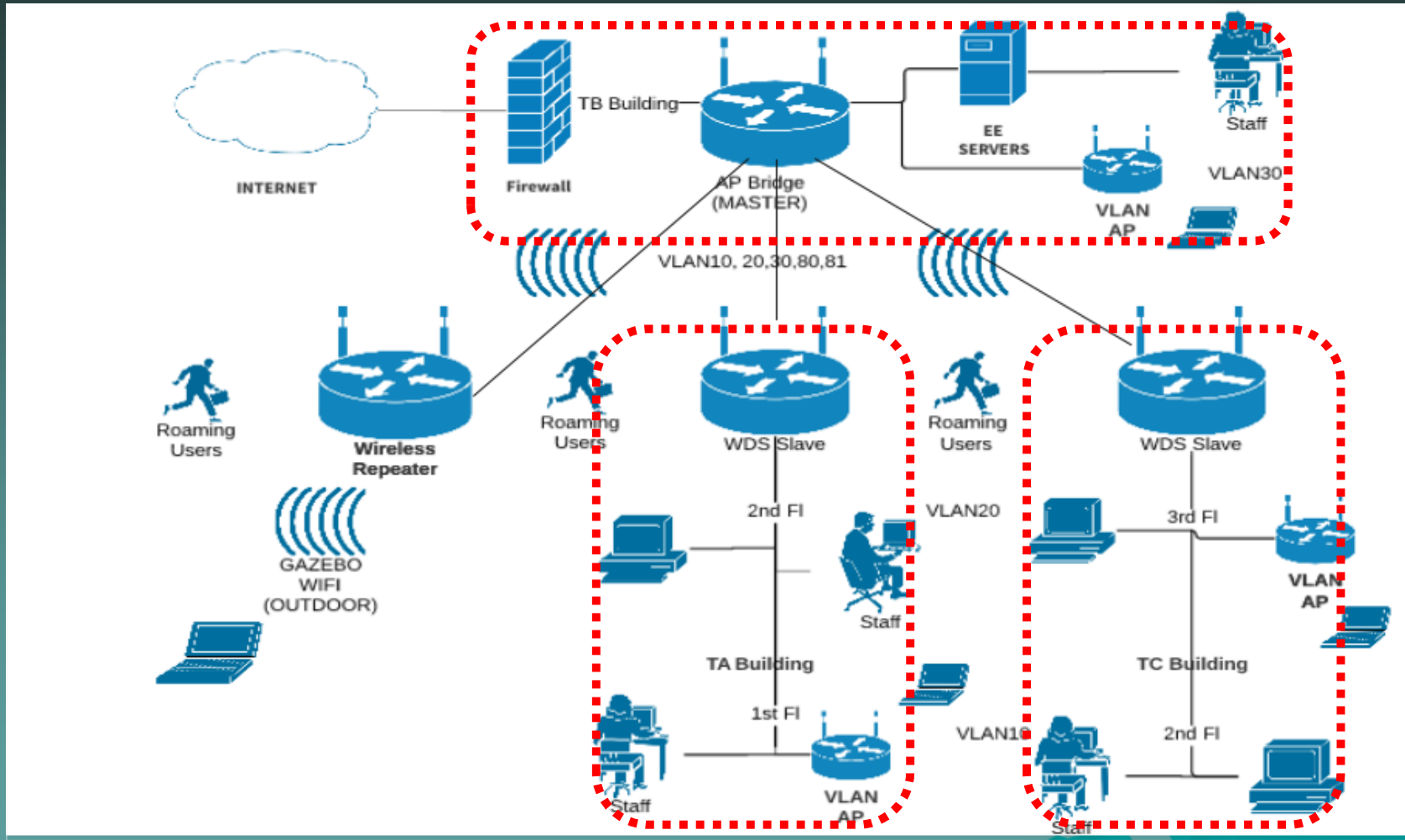

Hardware Type

- ◆ CRS 226-24G-2S-IN
- ◆ CRS 125-24G-1S-2HnD-IN
- ◆ RB 2011UiAS-2HnD-IN
- ◆ RB 952 Ui-5ac2nD
- ◆

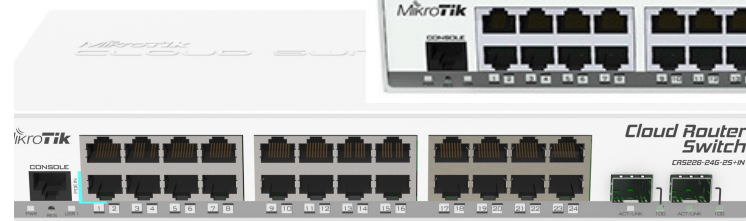
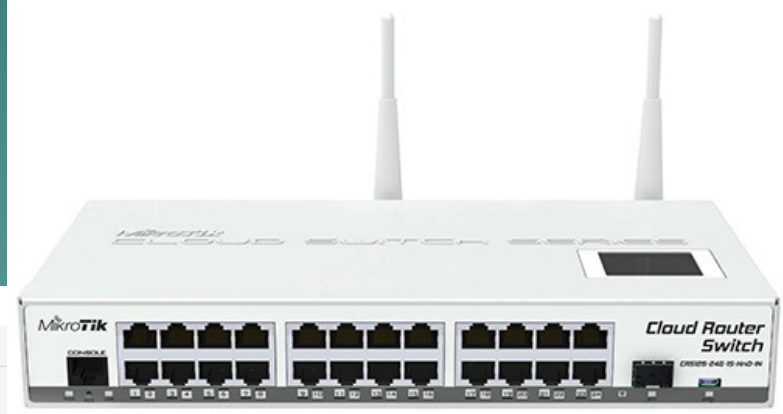

VLAN ID Planning

- ◆ VLAN 10: used for **faculty** management staff and or laboratory administrator.
- ◆ VLAN 20: used for **lecturers** in TA, TB and TC buildings
- ◆ VLAN 30: used for **student** in **laboratory or class** in TA, TB and TC building
- ◆ VLAN 80, 81: used for **roaming** student and or **outdoor** gazebo area

VLAN BRIDGES Planning

◆ For TRUNK

Bridge-Trunk : Ether1-2

Bridge-TrunkWL : Wlan1,2

◆ For ACCESS

BridgeVlan10: Ether 3-8 : VLAN 10

BridgeVlan20: Ether 9-16 : VLAN 20

BridgeVlan30: Ether 17-24 : VLAN 30

BridgeVlan8x: Wlan1,2 : VLAN 80, 81

VLAN ACCESS Port Planning

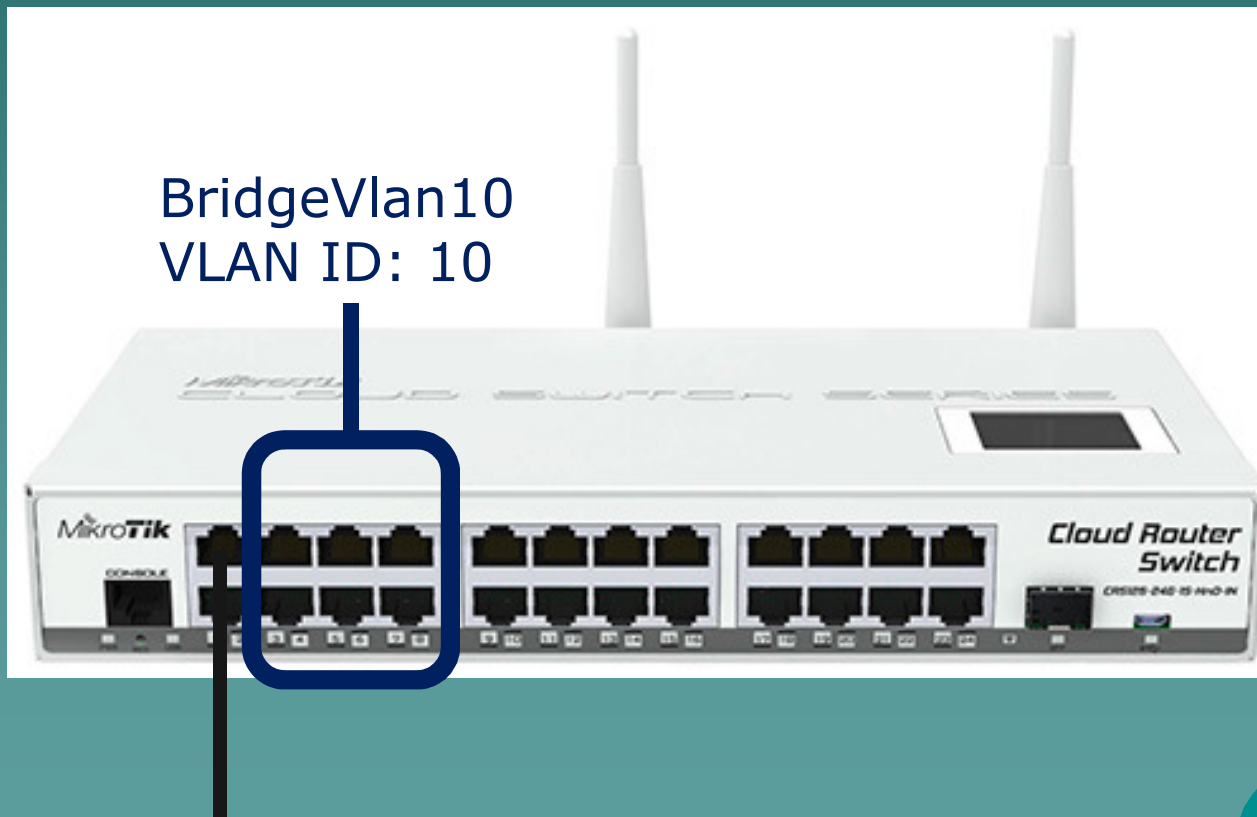

VLAN ACCESS Port Planning

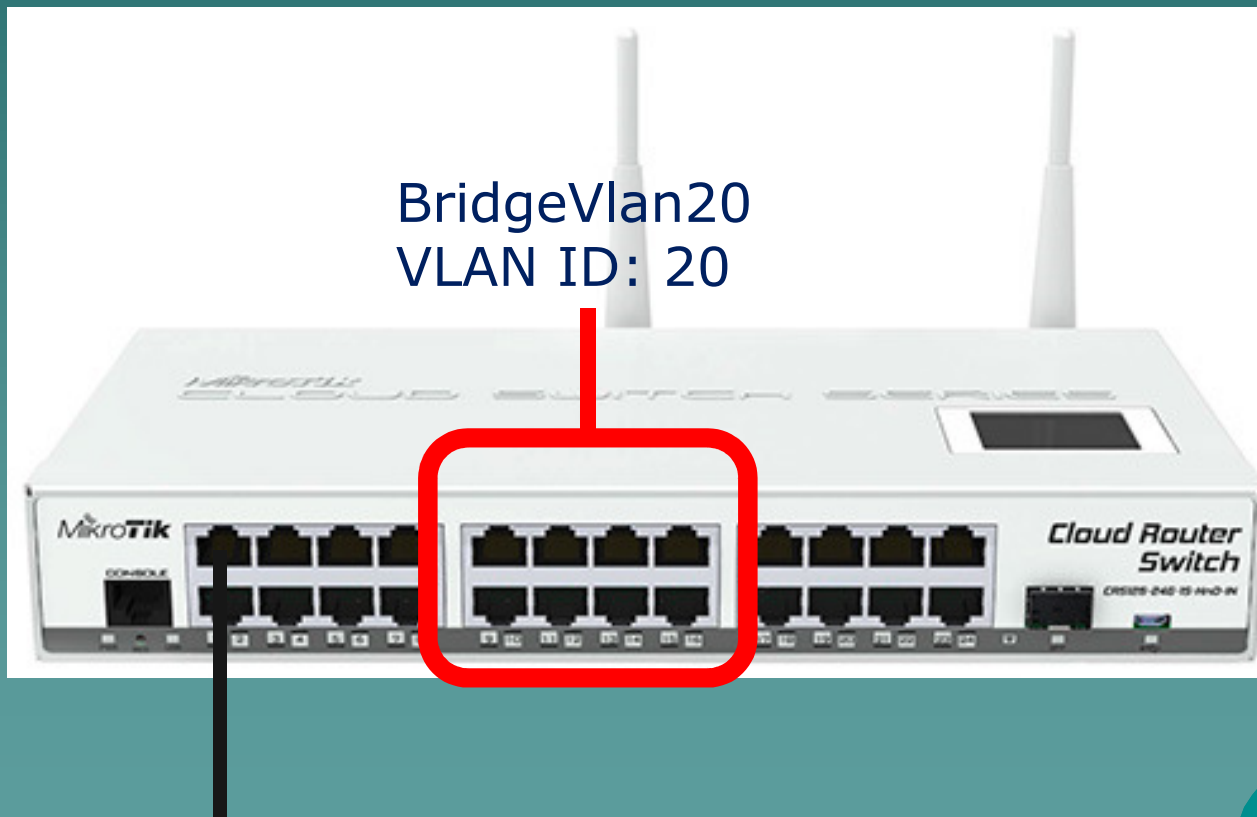

VLAN ACCESS Port Planning

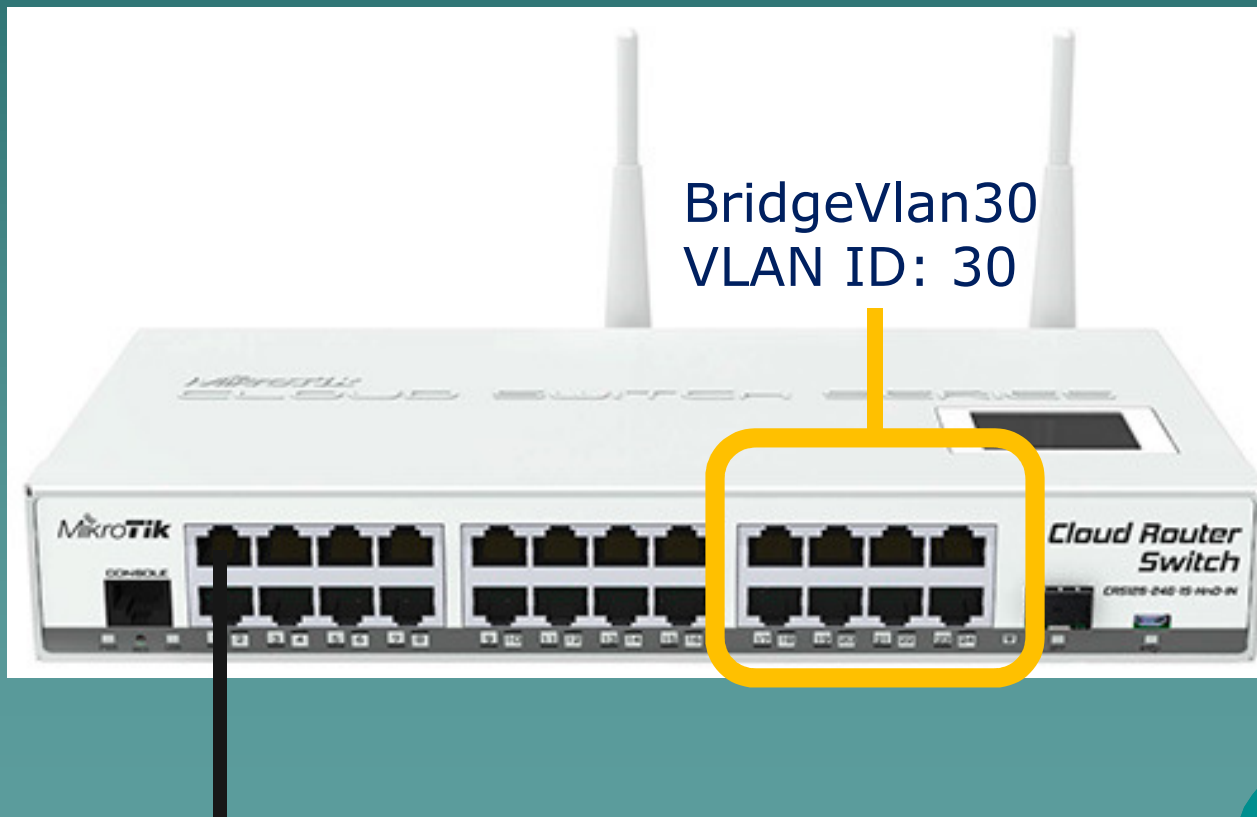

VLAN ACCESS Port Planning

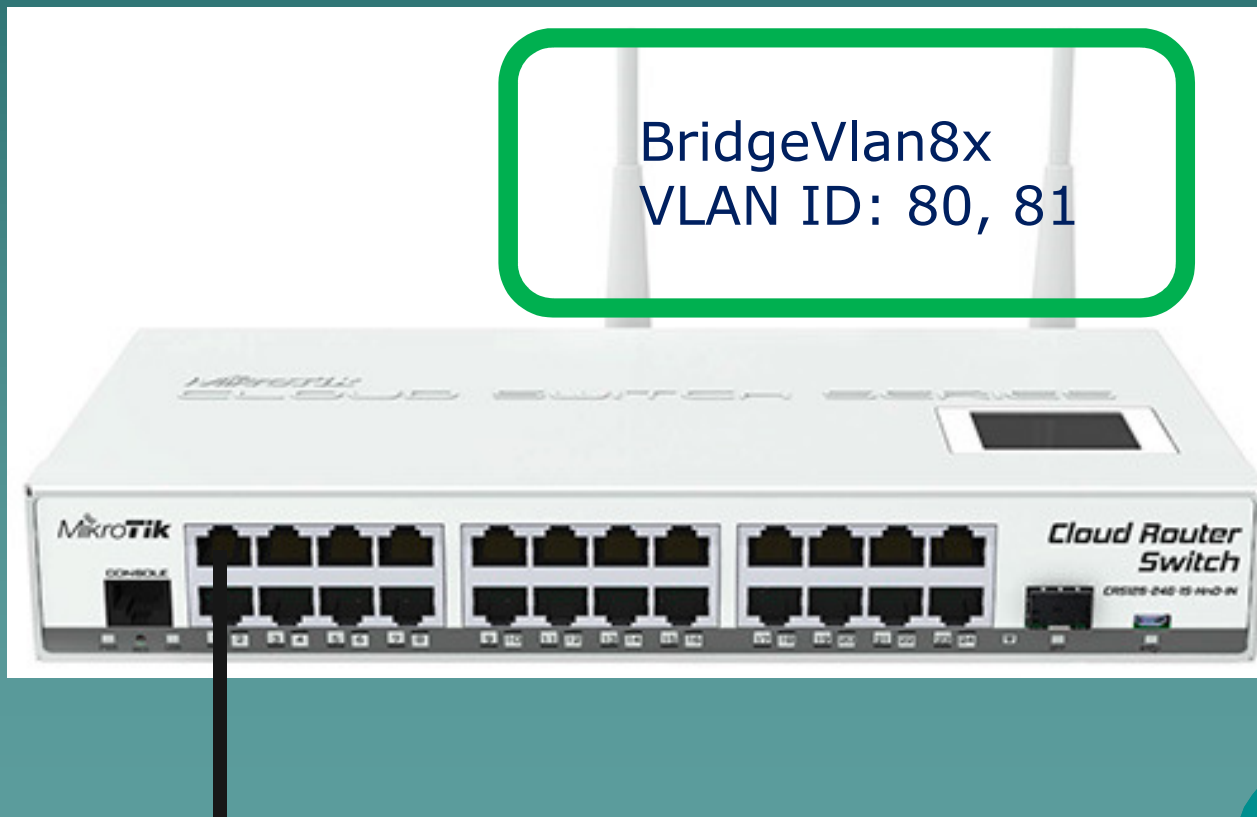

VLAN ACCESS Port Planning

WIRELESS ACCESS (VLAN 80 or VLAN 81)



ROUTERs TA

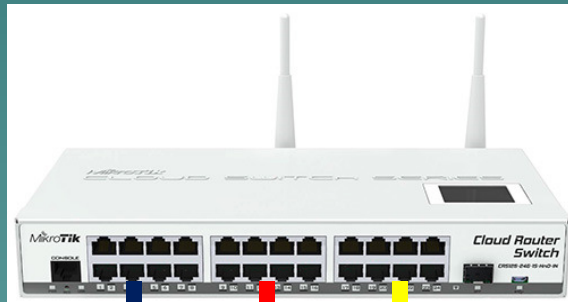

ROUTERs TB

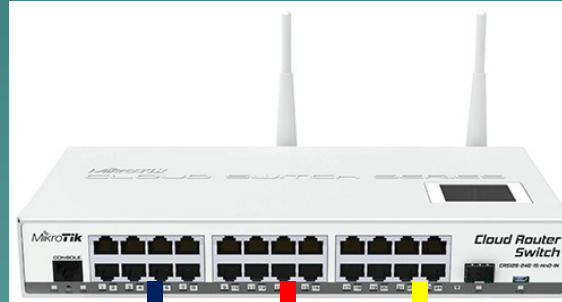

ROUTERs TC

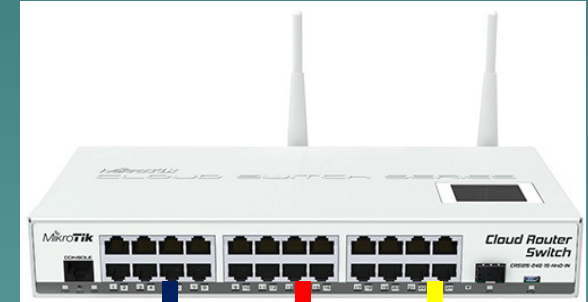

WIRED ACCESS

WIRED ACCESS

VLAN10 20 30

VLAN10 20 30

VLAN10 20 30

VLAN TRUNK Planning

WIRELESS TRUNK (VLAN 80, VLAN 81)



ROUTERs TA

ROUTERs TB

ROUTERs TC

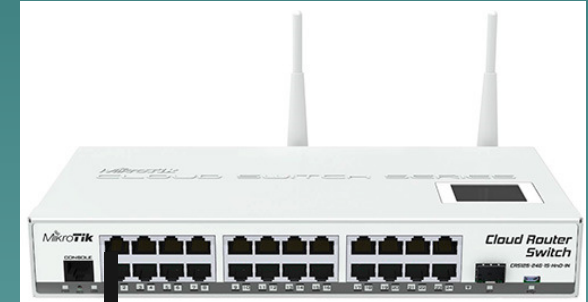
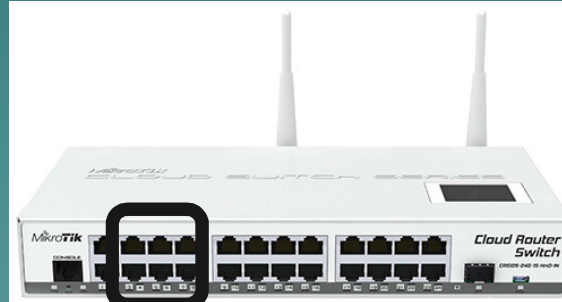
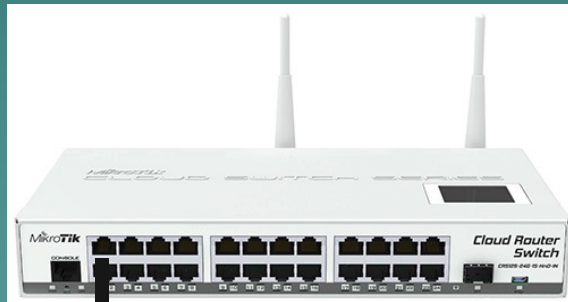

WIRED TRUNK

VLAN 10, 20 30

WIRED TRUNK

VLAN Overall Planning

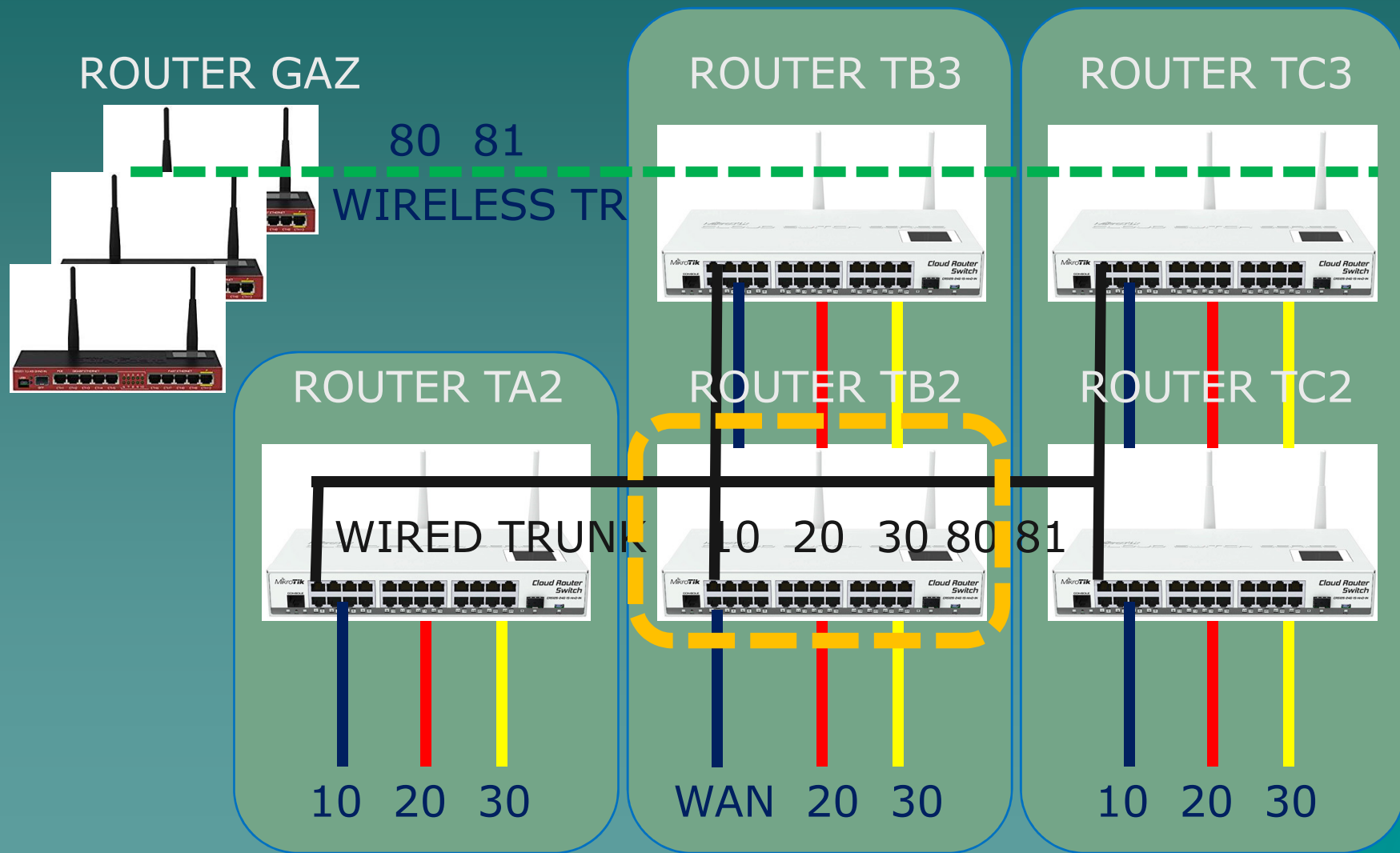

VLAN 10, 20, 30 Plan

- ◆ Use for indoor or internal building users (student, laboratory, lecturer, administration staff)
- ◆ Use: **Wired trunk** (SFP and Ethernet trunk)
- ◆ Router TB2 as **Main Router**: Wan (ether1-2) Trunk (ether3-8)
- ◆ Router TAs, TBs, TCs, Outdoors as **Access Router**: Trunk (ether1-2), Access Vlan (10: ether 3-8, 20: ether 9-16, 30: ether 17-24)

Router TB2 (Main Router)

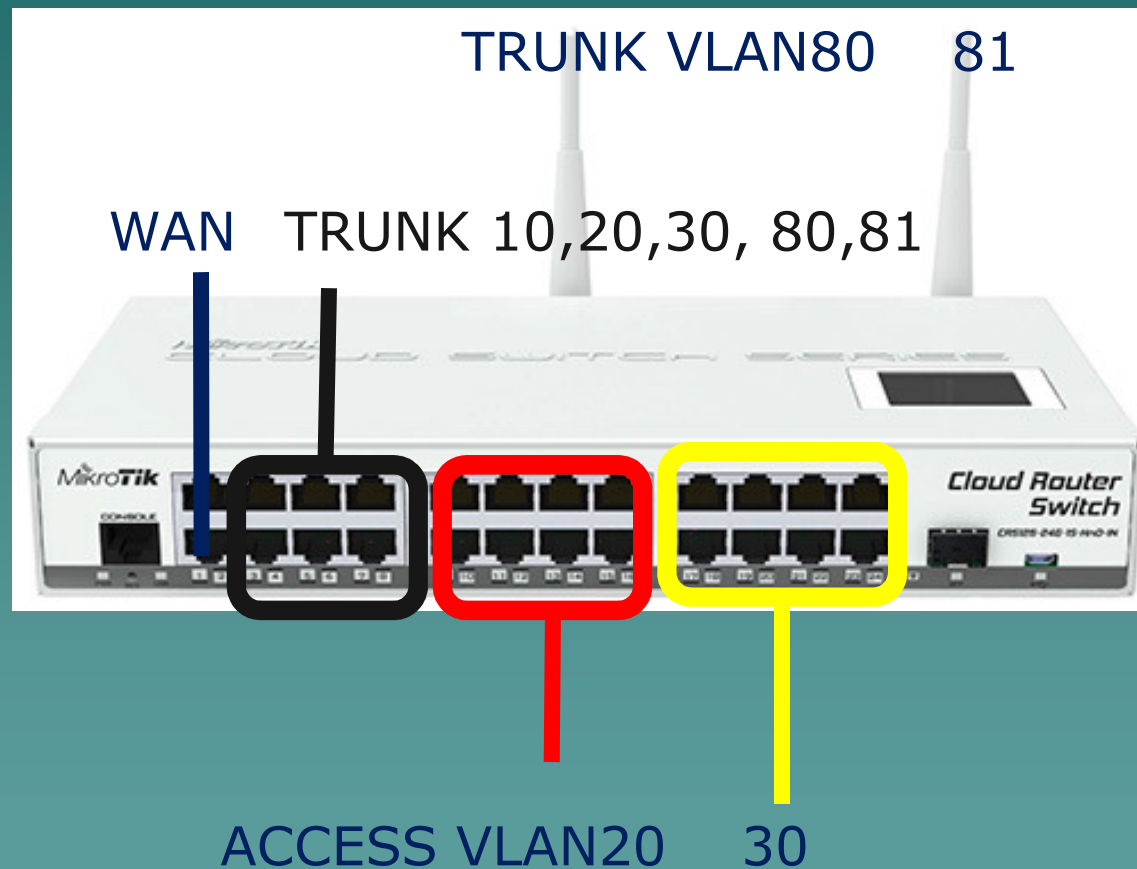

Router TAs, TBs, TCs (Access)

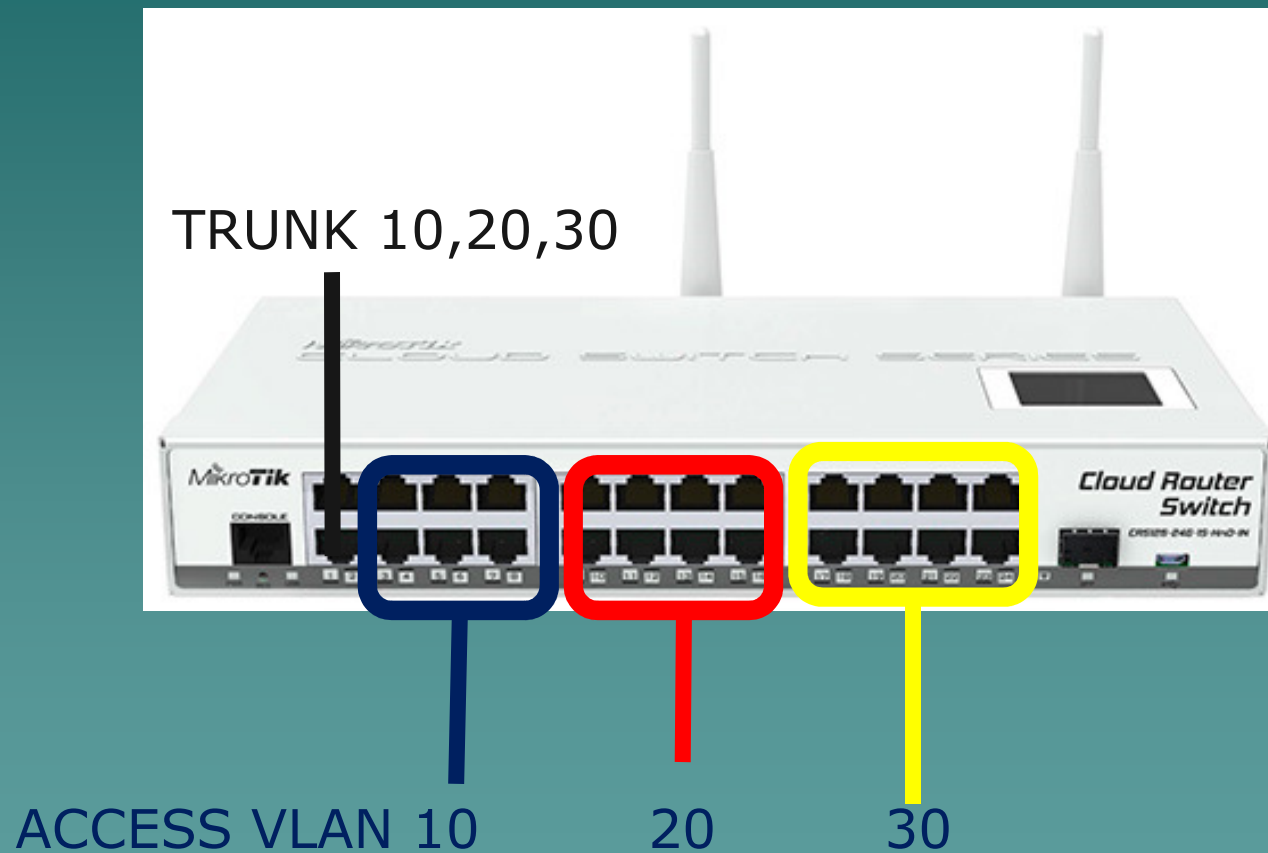

VLAN 80, 81 Plan

- ◆ Only **use for Roaming** Student between building TA, TB and TC (vlan 80 and 81)
- ◆ Use: **Wireless Trunk** - Repeater, AP Bridge, WDS (Master - Slave)
- ◆ Router TB: as WDS Master (AP-Bridge)
- ◆ Router Outdoor Gazebo: as WDS Slave
- ◆ Router Indoor Wireless: AP-Bridge, Station-Bridge, Repeater

VLAN Planning (Vlan 80, 81)

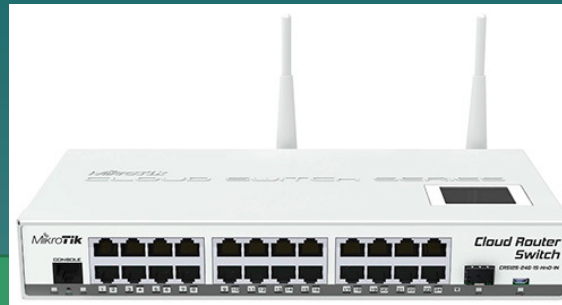

ROUTER TB

AP BRIDGE

WDS and/or Repeater

ROUTER GAZ1

ROUTER GAZ2

ROUTER GAZ3



WDS SLAVE



REPEATER



WDS SLAVE

Main Router (TB2) Configuration

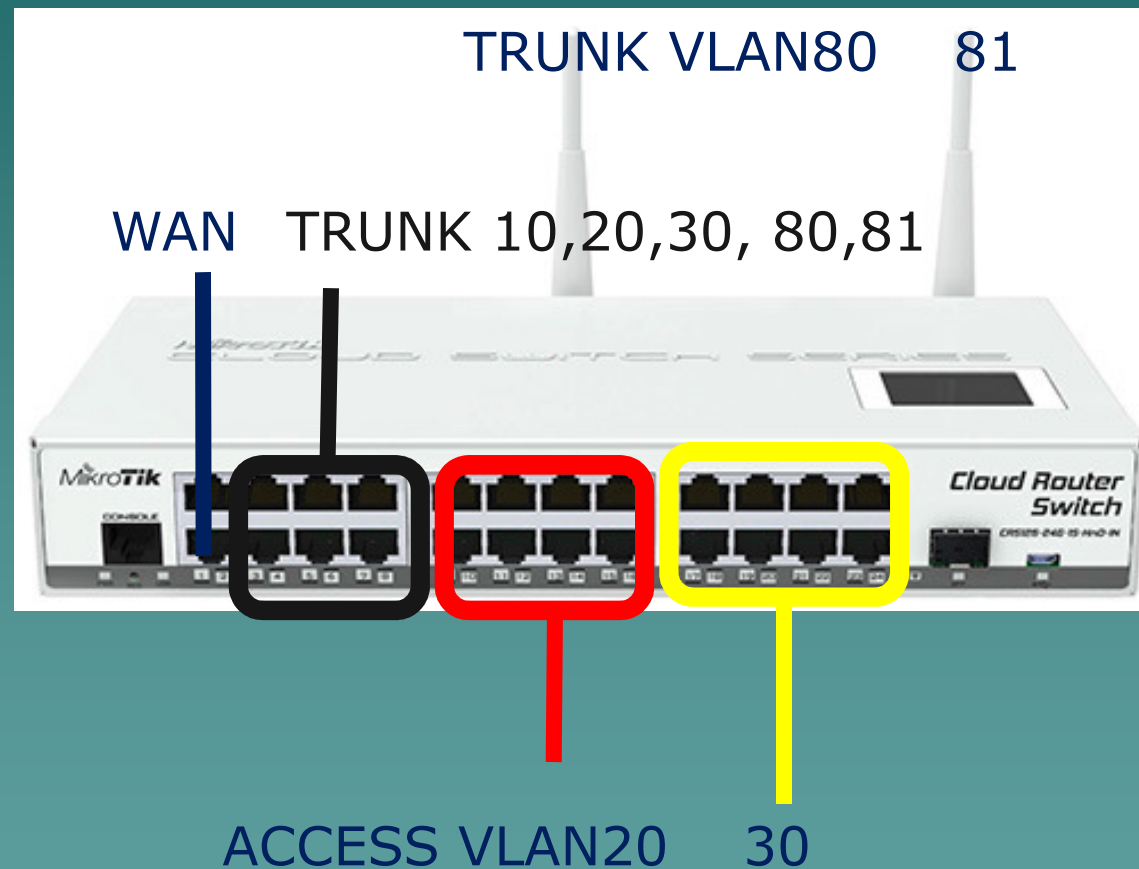

Main Router (TB2) Configuration

1) To be able to forward tagged packet, we need to create trunk bridge and access bridge.

```
/interface bridge
add fast-forward=no name=bridge-trunk
add fast-forward=no name=bridge-trunkwl
add fast-forward=no name=bridgevlan10
add fast-forward=no name=bridgevlan20
add fast-forward=no name=bridgevlan30
add fast-forward=no name=bridgevlan80
add fast-forward=no name=bridgevlan81
```

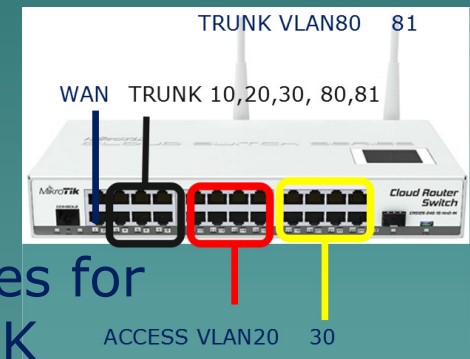

Bridges for
TRUNK

Bridges for
ACCESS

Main Router (TB2) Configuration

2a) Create VLAN interface in the trunk bridge

```
/interface vlan
```

```
add interface=bridge-trunk name=vlan10 vlan-id=10
```

```
add interface=bridge-trunk name=vlan20 vlan-id=20
```

```
add interface=bridge-trunk name=vlan30 vlan-id=30
```

```
add interface=bridge-trunk name=vlan80 vlan-id=80
```

```
add interface=bridge-trunk name=vlan81 vlan-id=81
```

```
add interface=bridge-trunkwl name=vlan80w vlan-id=80
```

```
add interface=bridge-trunkwl name=vlan81w vlan-id=81
```

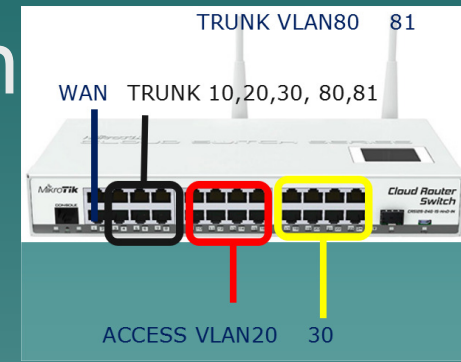

Wired
Trunk

Wireless
Trunk

Main Router (TB2) Configuration

2b) Add ethernet (ether3-8) port that we want to forward the VLAN in the trunk bridge

```
/interface bridge port
add bridge=bridge-trunk interface=ether3
add bridge=bridge-trunk interface=ether4
add bridge=bridge-trunk interface=ether5
add bridge=bridge-trunk interface=ether6
add bridge=bridge-trunk interface=ether7
add bridge=bridge-trunk interface=ether8
```

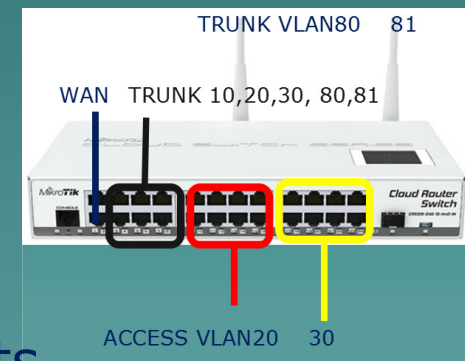

Ports
for
TRUNK

Main Router (TB2) Configuration

3a) Add ethernet (9-16) interfaces to the Vlan 20 access bridges and ethernet port (17-24) for Vlan 30

```
/interface bridge port
add bridge=bridgevlan20 interface=vlan20
add bridge=bridgevlan20 interface=ether9
add bridge=bridgevlan20 interface=ether10
.....
add bridge=bridgevlan20 interface=ether16
```

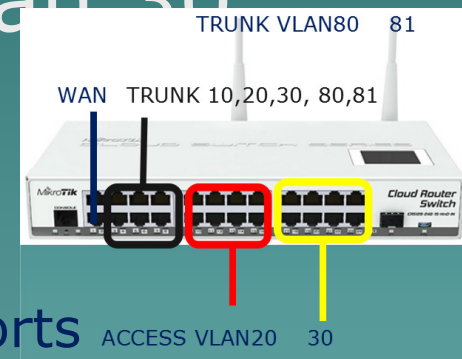

Ports
for
ACCESS
(ex: vlan20)

Main Router (TB2) Configuration

3b) Add ethernet (9-16) interfaces to the Vlan 20 access bridges and ethernet port (17-24) for Vlan 30

```
/interface bridge port
add bridge=bridgevlan30 interface=vlan30
add bridge=bridgevlan30 interface=ether17
add bridge=bridgevlan30 interface=ether18
.....
add bridge=bridgevlan30 interface=ether24
```

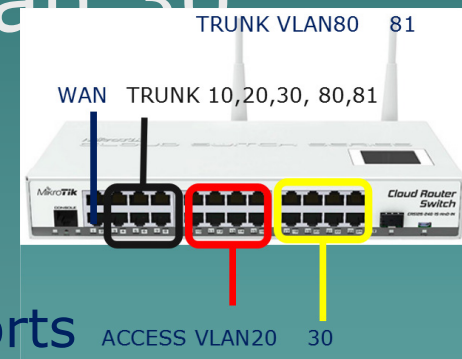

Ports
for
ACCESS
(ex: vlan30)

DHCP Configuration

- ◆ Give IP for each bridgevlan access then
- ◆ Create DHCP Server setup for interface bridgevlan10, 20, 30 and 80, 81 with specific IP Pool addresses.

```
/ip dhcp-server
```

```
add address-pool=dhcp_pool1 disabled=no interface=bridgevlan10  
name=dhcp1
```

```
add address-pool=dhcp_pool2 disabled=no interface=bridgevlan20  
name=dhcp2
```

```
.....
```

```
add address-pool=dhcp_pool5 disabled=no interface=bridgevlan81  
name=dhcp5
```

Network Configuration

- ◆ Make a masquerade NAT action output to WAN bridge interface.

```
/ip firewall nat
```

```
add action=masquerade chain=srcnat out-  
interface=bridge1wan
```

- ◆ Make necessary Firewall need.
- ◆ Make a default gateway route and IP Route for internal VLAN route if necessary.

Centralized Network Management

- ◆ Centralized DHCP Server
- ◆ Centralized QoS (Simple Queue, HTB)
- ◆ Centralized Route Management (Policy Routing, Route-Rules)
- ◆ Centralized Firewall (NAT, Filter, Mangle)
- ◆ Centralized Wireless Management (CapsMan)

Access Router Configuration (TAs, TCs, TBs)

Trunk: ether1, Access: ether 2-8 (10), 9-16(20),
17-24(30)

```
/interface vlan
```

```
add interface=bridge-trunk name=vlan10 vlan-id=10
```

```
add interface=bridge-trunk name=vlan20 vlan-id=20
```

```
add interface=bridge-trunk name=vlan30 vlan-id=30
```

```
add interface=bridge-trunk name=vlan20 vlan-id=80
```

```
add interface=bridge-trunk name=vlan30 vlan-id=81
```

```
/interface bridge port
```

```
add bridge=bridge-trunk interface=ether1
```

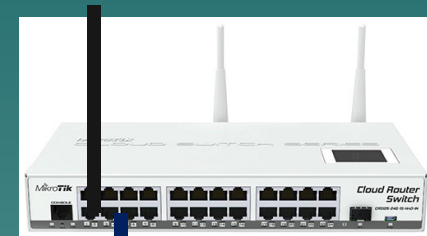

10 20 30

TRUNK port
(ex: ether1)

Access Router Configuration (TAs, TCs, TBs)

Trunk: ether1, Access: ether 2-8 (10), 9-16(20),
17-24(30)

```
/interface bridge port
add bridge=bridgevlan10 interface=vlan10
add bridge=bridgevlan10 interface=ether2
.....
add bridge=bridgevlan10 interface=ether8
.....
add bridge=bridgevlan30 interface=vlan30
add bridge=bridgevlan30 interface=ether17
.....
add bridge=bridgevlan30 interface=ether24
```

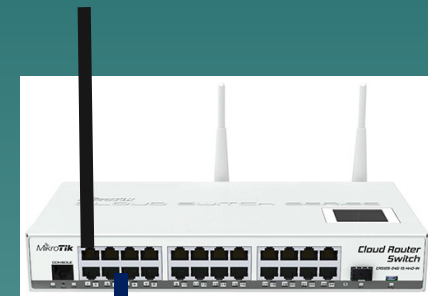

Ports
for
ACCESS 10 20 30

Access Router Configuration (GAZs, Outdoors)

Trunk: wlan1, WDS: Master-Slave
Create Vlan80, 81 on WDS Bridge

```
/interface bridge
add fast-forward=no name=bridge2wds
/interface bridge port
add bridge=bridge2wds interface=wlan1
/interface vlan
add interface=bridge2wds name=vlan80 vlan-id=80
add interface=bridge2wds name=vlan81 vlan-id=81
/interface wireless wds
add disabled=no master-interface=wlan1 name=wds1 wds-
address=D4:CA:6D:0C:26:CA
add disabled=no master-interface=wlan1 name=wds2 wds-
address=4C:5E:0C:32:76:4F
```

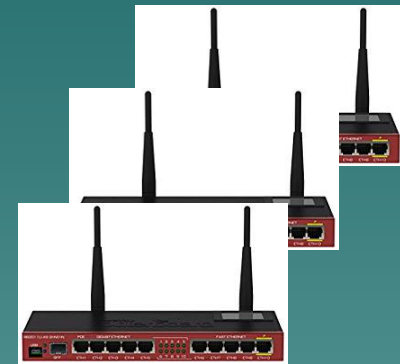

Conclusion & Discussion

- ◆ Bridging vlan (wired and wireless) makes **network management easier and centralized**.
- ◆ VLAN could be put or attached **in bridge or physical interface**.
- ◆ When you **add an interface to a bridge, the bridge becomes the master** interface and all bridge ports become slave ports, this means that all traffic that is received on a bridge port is captured by the bridge interface and all traffic is forwarded to the CPU using the bridge interface instead of the physical interface.

Conclusion & Discussion

- ◆ With bridges, it is easy to show and manage the trunk port or access port.
- ◆ Always **disable VLAN filtering** first, before you are sure about your VLAN setting !
- ◆ Always **give the specific IP to the bridges** for ease of maintenance and trouble-shooting.
- ◆ **Bridging in wireless**, we should use station-bridge or bridge mode, don't use station only mode.
- ◆ The **disadvantage of wds and repeater link** is the reduction of the throughput on the wireless side.

References

- ◆ <https://wiki.MikroTik.com/wiki/Manual:Interface/VLAN>
- ◆ https://wiki.mikrotik.com/wiki/Manual:Interface/Bridge#Bridge_VLAN_Filtering
- ◆ https://wiki.mikrotik.com/wiki/Manual:Layer2_misconfiguration
- ◆ https://wiki.mikrotik.com/wiki/Manual:Interface/Bridge#Management_port
- ◆ https://wiki.mikrotik.com/wiki/Vlans_on_Mikrotik_environment
- ◆ https://en.wikipedia.org/wiki/Wireless_distribution_system
- ◆ https://wiki.MikroTik.com/wiki/WDS_repeater_example



Credit to

- ◆ MikroTik and MUM Yogyakarta 2018 Committee
- ◆ Telecommunication and Network Design Laboratory (TND - Ubaya)
- ◆ Mr. Herry Darmawan and Team
- ◆ Elektro UBAYA Training Center (EUTC)
- ◆ My Colleagues



UBAYA
UNIVERSITAS SURABAYA

*Mikro***Tik**

Thank you