

MASSIVE DEPLOYMENT OF MIKROTIK ROUTER BOARDS FOR WIRELESS/CABLE SERVICE PROVISION IN A VERY NOISY ENVIRONMENT



Campus Best Practice

URAN Association
GN4 Campus Best Practice Project

Viacheslav Shkarupin
slava@kar.net

Kiev 2015

Organizations

Association of Users of Ukrainian Research and Academic Network: coordination and integration of efforts of the Association Members to ensure creation, development and usage of the Ukrainian National Research and Education Network

<http://uran.ua/~eng/frames.htm>



Campus Best Practice is a part of the GÉANT project funded by the European Union. Campus Best Practice (CBP) aims to address key challenges for European campus networks.



Campus Best Practice

<http://services.geant.net/cbp/Pages/Home.aspx>

Prerequisites

- ⦿ Project Goal: Unlimited access to services for all inhabitants of a student's dormitory.
- ⦿ Building parameters: 9 story concrete tower; leaving areas on floors 2 – 9; 16 rooms per floor, 128 rooms total; 500 – 600 dwellers.
- ⦿ Building layout: staircase and elevators in the middle, two wings with 8 rooms in each, length of hallways on both sides approx 35 m.
- ⦿ Technology : WiFi (full coverage of all leaving areas) and Cable (one connection) to every leaving room in the building

Why the Choice? – Initial Considerations

Priority list of equipment features:

- PoE (no separate power cables to equipment)
- Internal antenna (not possible to highjack the sticking out part)
- UTP ports (need to have cable connections to all rooms)
- Immediate availability in Ukraine (project launch deadline)
- Unit price fits budget limits (just as always – never enough money)

Options considered: practically all available vendors, only one found to satisfy the above requirements: MikroTik RB951Ui-2HnD

Sometimes lack of knowledge leads to correct solutions!

The MikroTik RB951Ui-2HnD

**Most important specifications
(at the design stage of the project):**

- **PoE**
- **Internal Antenna**
- **Five 10/100 Ethernet ports**
- **Max Power consumption 7 W**
- **Suggested price \$59.95**



Other parameters important, but not decisive

Physical Layout: Mounting

In order to provide full WiFi coverage 4 MikroTik RB951Ui-2HnD units were mounted on each floor of the building. Overall 32 devices were deployed.

One equipment rack on the 5-th floor:

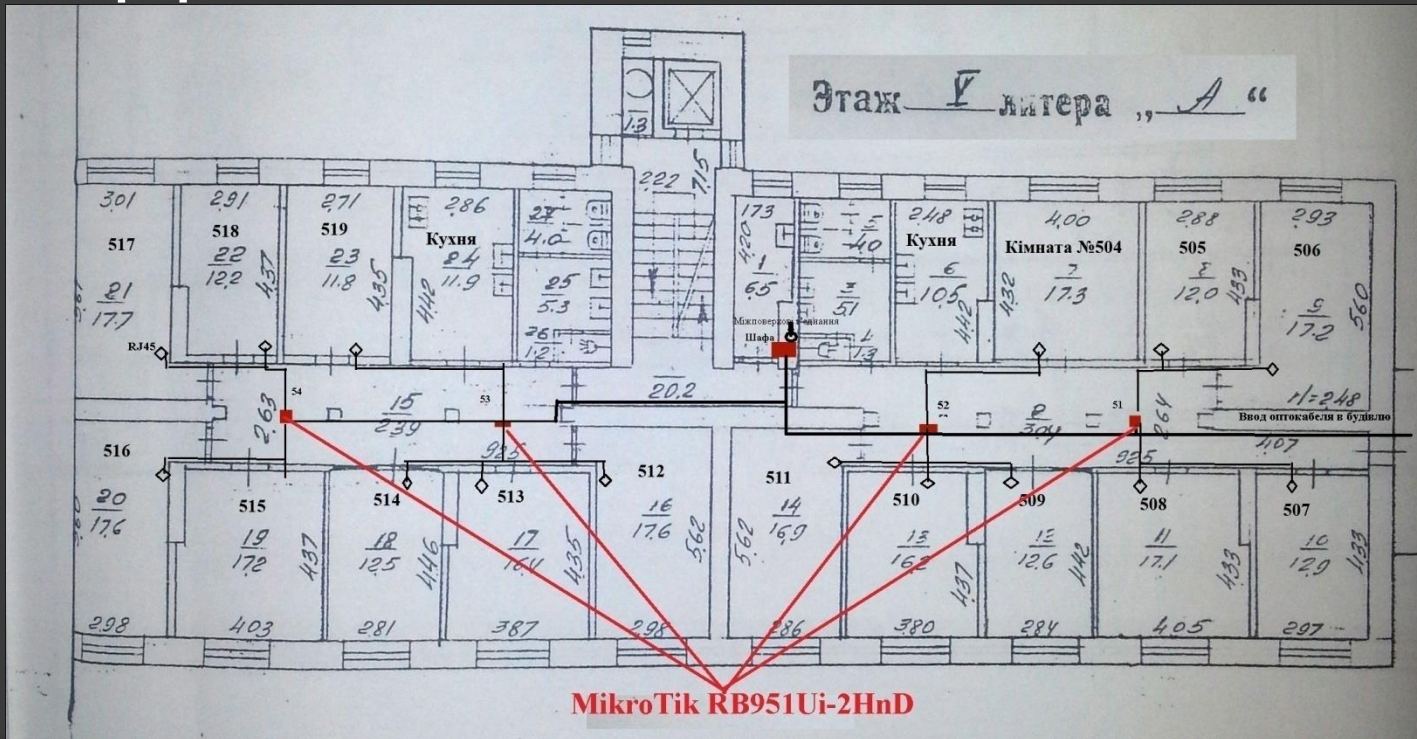

Physical Layout: The Circuit

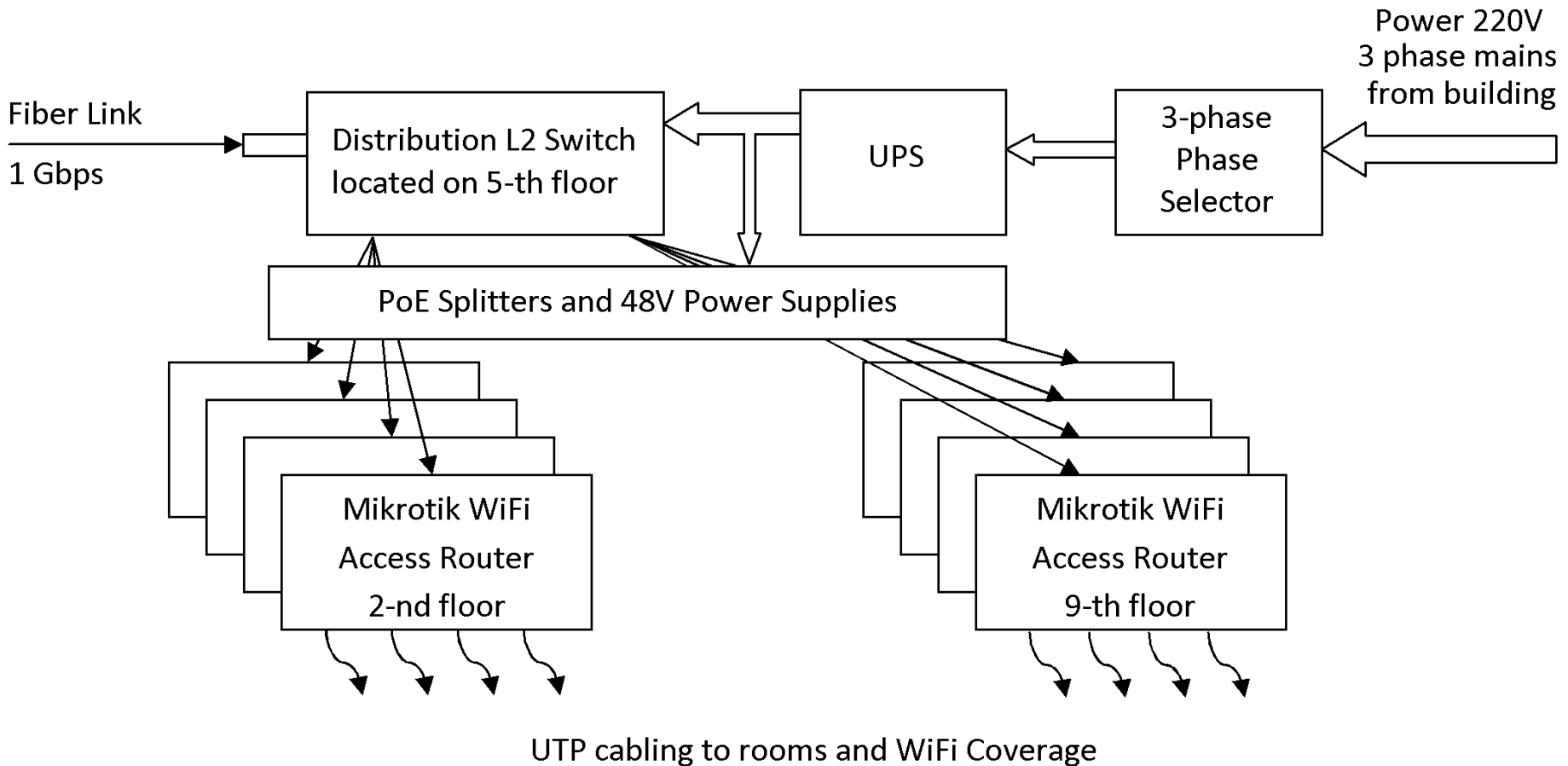

Logical Structure of Network

Uniform for all 32 MikroTik devices:

- ⦿ Internal VLAN for Monitoring-Management of MikroTik router boards and distribution switches
- ⦿ Separate VLAN for service provision
- ⦿ Real IP address for each device
- ⦿ Gray IP addresses for device management
- ⦿ Routing provided by access server
- ⦿ NATed address space for users
- ⦿ HotSpot for both WiFi and Cable access
- ⦿ User Area WEB server
- ⦿ Access controlled by Billing server

Monitoring and Management

- Dude & MikroTik tools used for Monitoring and Management

But: performing some tasks is not straightforward, e.g. checking wireless and cable registrations at a glance

- Self-coded API-based applications used for monitoring specific parameters

Monitoring and Management: the Dude

Customized the Dude for our needs:



Monitoring and Management: API

- Coded in pure ANSI C using MikroTik provided API
- Runs on *NIX and Windows platforms
- Allows monitoring WiFi and Cable registrations + other data

```
PM91
PM0522 192.168.43.135 D0:DF:9A:D2:8B:5F WiFi http-pap 1h34m3s
PM0488 192.168.43.143 9C:B7:0D:7C:77:7C WiFi mac-cookie 7m35s

PM92
PM0103 192.168.43.178 C4:6E:1F:7A:48:41 Cable http-pap 1w2d22h3m16s

PM93
PM0526 192.168.43.207 00:16:EA:B4:AB:E0 WiFi mac-cookie 1h12m13s
PM0481 192.168.43.215 2C:D0:5A:16:83:63 WiFi http-pap 55m19s
PM0456 192.168.43.221 20:89:84:EB:B7:F0 Cable http-pap 1h26m33s

PM94
PM0163 192.168.43.243 6C:5F:1C:3E:3C:55 WiFi mac-cookie 2m40s
PM0491 192.168.43.247 64:B3:10:BF:6E:58 WiFi http-pap 11h48m44s

Stringlength of Table = 3526
#of connected users = 51
#of WiFi users = 34
Time is: 17-11-2015 10:10

C:\Windows\system32>
```

Monitoring and Management: WEB-Based

- Coded: PHP – Thrift – Java – Scala – Oracle + API
- Integrated with a tool-set on a Management Website

Users Table					
	Login	IP	Device	Uptime	Inspected
1	PM0017	192.168.40.198	PM33	36512	2
2	PM0018	192.168.40.230	PM34	1013983	174
3	PM0022	192.168.42.245	PM74	83069	176
4	PM0023	192.168.42.248	PM74	1445403	176
5	PM0040	192.168.43.84	PM83	77679	163
6	PM0041	192.168.43.88	PM83	1467060	163
7	PM0050	192.168.41.107	PM44	82849	1
8	PM0058	192.168.40.201	PM33	1543	2
9	PM0067	192.168.41.121	PM44	1116	1
10	PM0094	192.168.41.61	PM42	829	169
11	PM0103	192.168.43.178	PM92	1459543	177
12	PM0104	192.168.42.25	PM61	3447	162
13	PM0131	192.168.42.175	PM72	1730	166
14	PM0158	192.168.43.68	PM83	548818	163
15	PM0160	192.168.41.177	PM52	1437	3

Monitoring and Management: Future Development

- Crowed-Sourced network performance assessment
- User devices used for gathering statistical information
- Cookie injection: adds or user site
- Processing: collected data + device and server logs
- Will provide a view from the users standpoint

The WiFi versus Cable Trend

Where the noise comes from

During the years of operation the number of connected WiFi devices (users) has grown rapidly, number of Ethernet connections (users) has decreased.

Extra% << What is this?

Percentage of connected WiFi and Ethernet users

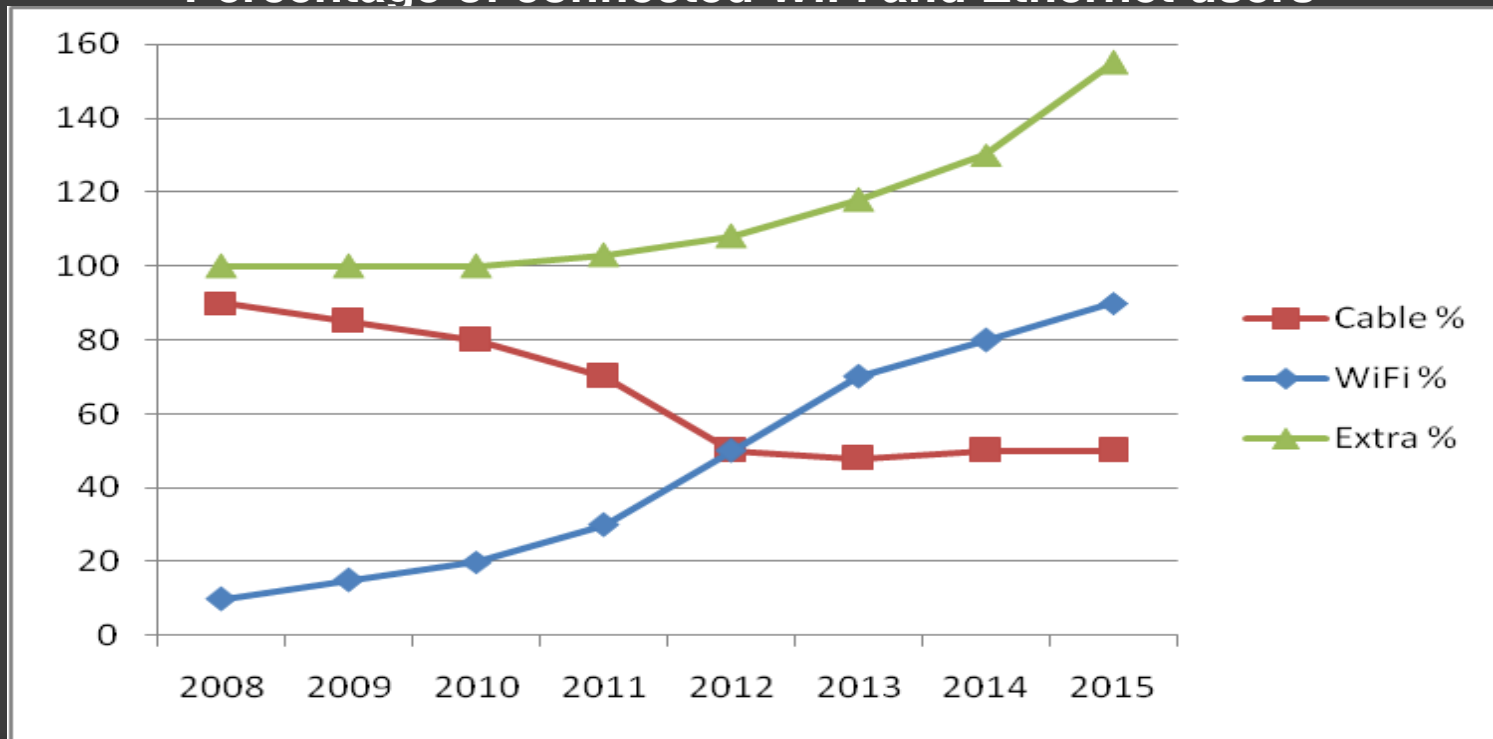

Environment: the Noise

Spectral density measured on one of the devices

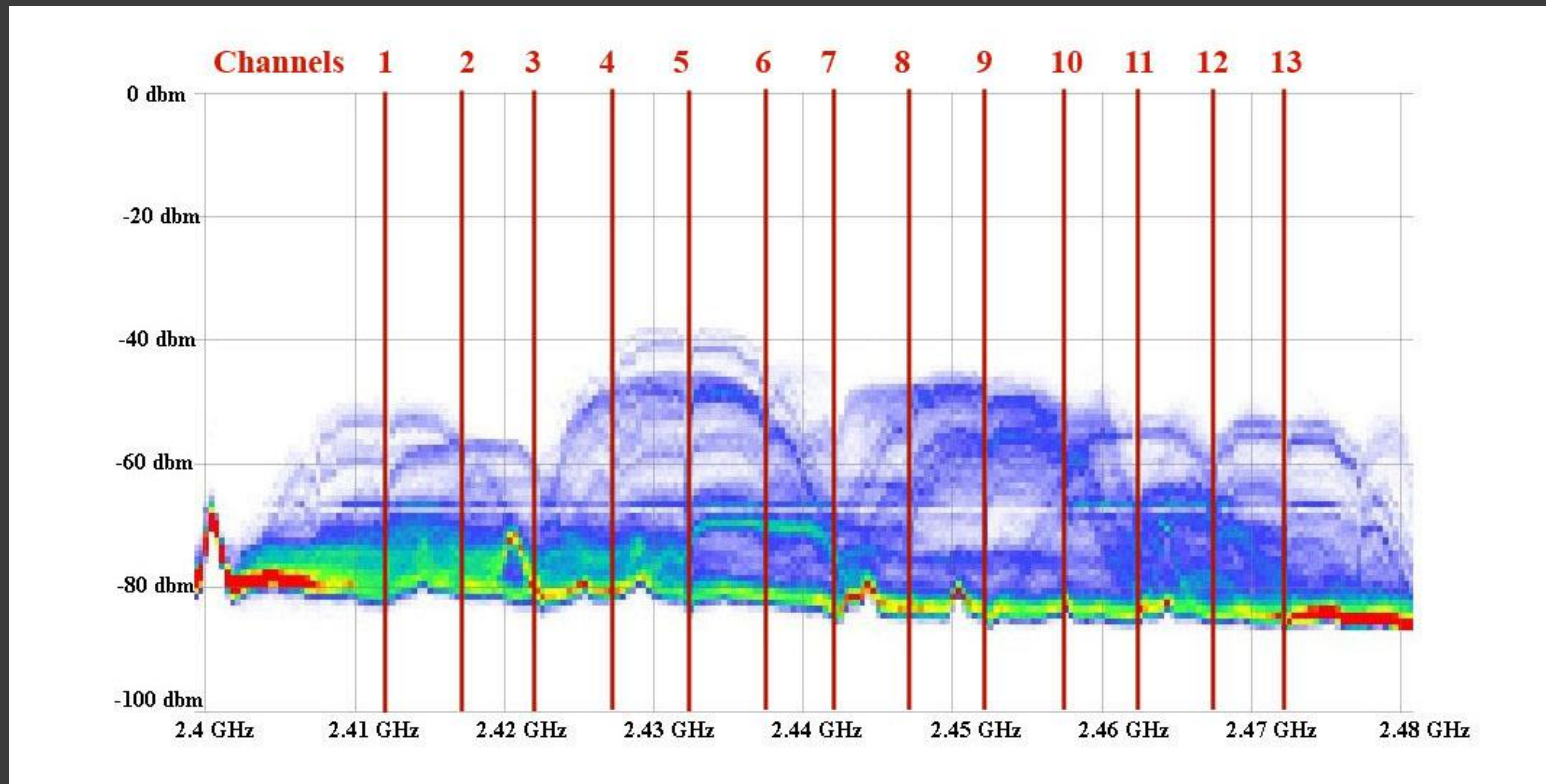

Environment: the Noise Source

Dude -> Tools -> Winbox -> Wireless -> Interface (Wlan1) -> Scan

	Address	SSID	Band	Chan...	Frequ...	Signal Str...	Noise Floor	Signal To Noise	Radio Name	RouterC
AP	CU:4A:00:7C:5E:B2	Warp	2GHz-B/G/N	20MHz	2417	-91	-102	11		
P	C0:4A:00:7C:5E:B2	Warp	2GHz-B/G/N	20MHz	2457	-89	-101	12		
P	E8:94:F6:B7:C8:B0	Yalta	2GHz-B/G/N	20MHz	2442	-83	-95	12		
P	00:1A:70:47:BE:0D	ZTulupova	2GHz-B/G/N	20MHz	2442	-96	-95	-1		
P	10:FE:ED:9E:BC:F4	Zaparolen	2GHz-B/G/N	20MHz	2412	-91	-96	5		
AP	BC:EE:7B:80:A2:B4	ami	2GHz-B/G/N	20MHz	2467	-89	-96	7		
P	82:36:8B:C8:33:8A	conyaka348	2GHz-B/G/N	20MHz	2412	-74	-96	22		
P	42:4B:97:CA:B5:C4	conyaka348	2GHz-B/G/N	20MHz	2412	-72	-96	24		
P	2E:B7:54:64:E5:AA	conyaka348	2GHz-B/G/N	20MHz	2412	-70	-96	26		
P	76:F8:8F:F0:7E:C8	conyaka348	2GHz-B/G/N	20MHz	2412	-68	-96	28		
P	90:F6:52:41:71:87	dexter	2GHz-B/G/N	20MHz	2437	-98	-102	4		
P	00:1C:F0:3D:6C:E9	dlink102	2GHz-B/G/N	20MHz	2437	-88	-102	14		
AP	38:2C:4A:46:45:BC	gg	2GHz-B/G/N	20MHz	2472	-87	-104	17		
AP	C4:A8:1D:DD:21:24	hostel	2GHz-B/G/N	20MHz	2452	-74	-102	28		
P	F8:D1:11:33:63:9E	iHome	2GHz-B/G/N	20MHz	2412	-90	-96	6		
P	AC:22:0B:8F:48:E4	karina	2GHz-B/G/N	20MHz	2412	-92	-96	4		
P	90:F6:52:C6:3D:65	ksenia	2GHz-B/G/N	20MHz	2472	-92	-104	12		
AP	AC:22:0B:8F:5A:7C	nam_bez_raznicu	2GHz-B/G/N	20MHz	2447	-78	-100	22		
P	54:E6:FC:F2:76:F8	ruslan	2GHz-B/G/N	20MHz	2442	-80	-95	15		
P	14:CC:20:88:25:AE	semka	2GHz-B/G/N	20MHz	2452	-84	-102	18		
P	90:F6:52:8C:36:C4	ytko	2GHz-B/G/N	20MHz	2437	-87	-102	15		
P	14:CC:20:96:0E:02	zoloto	2GHz-B/G/N	20MHz	2437	-82	-102	20		
ARB	4C:5E:0C:23:3F:1D	PM34	2GHz-B/G/N	20MHz	2412	-87	-96	9	4C5E0C233F1D	6.22
ARB	05:55:0C:45:C3:CD	PM33	2GHz-B/G/N	20MHz	2412	-87	-96	9	05550C45C3CD	6.22

117 items

Why the Choice? – Production

- ⦿ Extremely reliable: once set-up does not require interventions
- ⦿ Recovers after power outages!
- ⦿ Management & Monitoring Apps available – the Dude + MikroTik tools
- ⦿ BUT! No further development of Dude
- ⦿ APIs for multiple programming languages
- ⦿ Leaves up to specifications in very noisy environments

System Users Perspective

- Availability of Management – Monitoring tools for MikroTic
- Very high resilience of Router Boards: no on-site servicing required
- Customized system – PHP front end; Scala/Oracle back end with Thrift and Protobuf in the middle
- Customized Radius for AAA and DHCP

End Users Perspective

- Self – registration for new customers:
Login-password credentials (Federation access in future)
- HotSpot access to services
- Secure on-line payments for services by credit cards
- Availability of URAN services
- Help - desk

THANK YOU!

Questions welcome:

Here and Now

or

slava@kar.net